

OneMount™ Advantage® Shear Beam Load Points

OneMount HI ONELP Load Points with HI SBH04 Hermetic Shear Beam Sensors

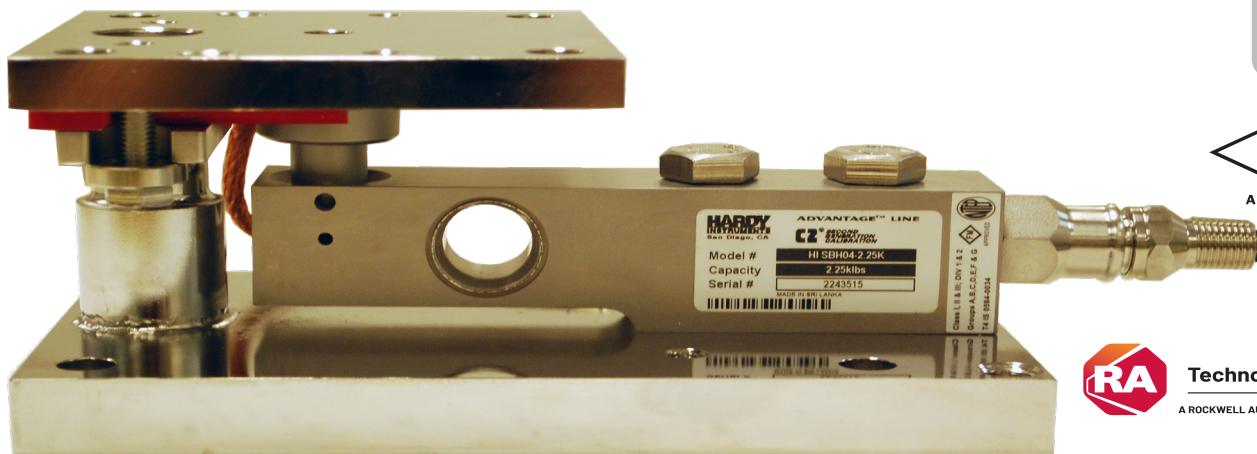

The Hardy OneMount™ with Advantage® shear beams are specifically built to save customers time and money during installation, calibration, and maintenance. Each load point provides extraordinary flexibility and durability in most industrial environments. Each feature of the load point was intentionally designed based on nearly 100 years of process weighing experience, delivering a best-in-class measurement system for vessel, hopper and tank weighing systems.

Accuracy

- Self-centering rocker design maintains alignment under considerable shear forces
- Precision sensor (combined error 0.02% rated output) from 1,125 lbs – 22,500 lbs (1.125/2.25/4.5/7.5/11.25/ 22.5 Klbs)
- Optional Dynamic Stabilization Rods can be purchased to reduce vibration noise on the sensor for better resolution

Safety

- Liftoff and side force ratings are confirmed by third party destructive testing
- True glass-to-metal hermetically sealed sensors deliver the ultimate washdown protection (IP68/IP69K)
- C2® electronic calibration reduces the risk of accidents or contamination from test weights

Easy Installation

- Integral spacers can carry the full rated capacity without the load cell installed, eliminating the need for expensive dummy load cells or welding fixtures
- Once mounts are installed, the load cells slide into place. With minimal tank jacking (1/8"), the spacers are removed for a live load point
- 360° checking mechanism means load points can be installed in any direction
- C2® electronic calibration for fast startup in high capacity installations

Easy Maintenance

- Replace load cells with minimal tank jacking (1/8")
- Matched mV/V/ohm load cells are easy to replace without recalibration

User Benefits

- OEE improvement from consistent, accurate performance, and reduced installation and maintenance time
- Reduced capital investment and labor typically associated with dummy load cells and welding fixtures
- Reduced complexity of system selection and installation from a single, universal design

All information and drawings on these pages are subject to change without notice. Consult website for latest specifications.

HI SBH04 ADVANTAGE® Load Sensor

SPECIFICATIONS	Units	HISBH04	HISBH04
Maximum Capacity (E _{max})	lbs	1.125k / 2.25k / 4.5k / 11.25k / 22.5k*	7.5k ¹
Max number verification intervals	n _{max}	3000	3000
Min load cell verification interval	v _{min}	E _{max} / 11000	E _{max} / 11000
Combined Error	%RO	± 0.0200	± 0.0200
Non-Linearity	%RO	± 0.0166	± 0.0200
Hysteresis	%RO	± 0.0166	± 0.0200
Creep error (30 Minutes) / DR	%RO	± 0.0166	± 0.017
Temp effect on min dead load output	%RO/10°C	± 0.0127	± 0.0200
Temperature effect on sensitivity	%RO/10°C	± 0.0100	± 0.0100
Non-Repeatability	%RO	Not Specified	Not Specified
Rated Output (RO)	mV/V	2 ± 0.1%	2.0 ± 0.2%
Calibration in mV/V/Ω		Matched	Matched
Zero Balance	%RO	± 5	± 5
Excitation Voltage	V	5-15	5-15
Input Resistance	Ω	1100 ± 50	1168 ± 30
Output Resistance	Ω	1000 ± 2	1000 ± 5
Insulation resistance (100VDC)	MΩ	≥ 5000	≥ 5000
Load Cell Safe Load Limit	%E _{max}	200	200
Load Cell Ultimate Load Limit	%E _{max}	300	300
Load Cell Safe Side Load	%E _{max}	100	100
Maximum Platform Size	N/A	N/A	N/A
Compensated Temperature Range	°C	-10 ... +40	-10 ... +40
Operating Temperature Range	°C	-40 ... +80	-40 ... +65
Load Cell Material		Stainless Steel 17-4PH (1.4548)	Stainless Steel
Sealing Glass to Metal Header		Hermetic Sealing	Hermetic Sealing
Protection according to EN 60 529		IP68 (up to 2m water depth) / IP69k	IP69
Cable Length	ft	20 ft	20 ft
Hazardous Certification		IS Class 1,2,3 Div 1	N/A
Legal For Trade		NTEP COC 99-057A1	NTEP

1. Uses 11,250lb mount. Minor differences in sensor size.

C2 WIRE COLOR CODE FLAG LABEL IS FOUND APPROX. 10 IN. FROM END OF SENSOR'S CABLE	
EXCITATION +	RED
EXCITATION -	BLACK
SIGNAL +	GREEN
SIGNAL -	WHITE
C2 +	GRAY
C2 -	VIOLET
SHIELD	YELLOW

WARNING: NEVER cut load sensor cable

* HISBH04-7.5K and HISBH04-22.5 are NOT FM Certified

HI ONEMT OneMount™

MOUNT SPECIFICATIONS	Units			
Capacity	lb	1125lb - 4500lb	11250lb	22500lb
Rated Liftoff Force*	lb	2250	5625	11250
Rated Overload*	lb	6750	16875	33750
Rated Side Force*	lb	4500	11250	22500
Weight Excluding Load Cell	lb	9	24	43
Material	Metallurgy	304SS Electropolished / 304SS Stainless Steel / Zinc Plated Steel		
Levelling Required		0.4/100 (legal for trade) / 0.8/100 (general applications)		

* Mount Specifications - Sensor specifications are limited by capacity

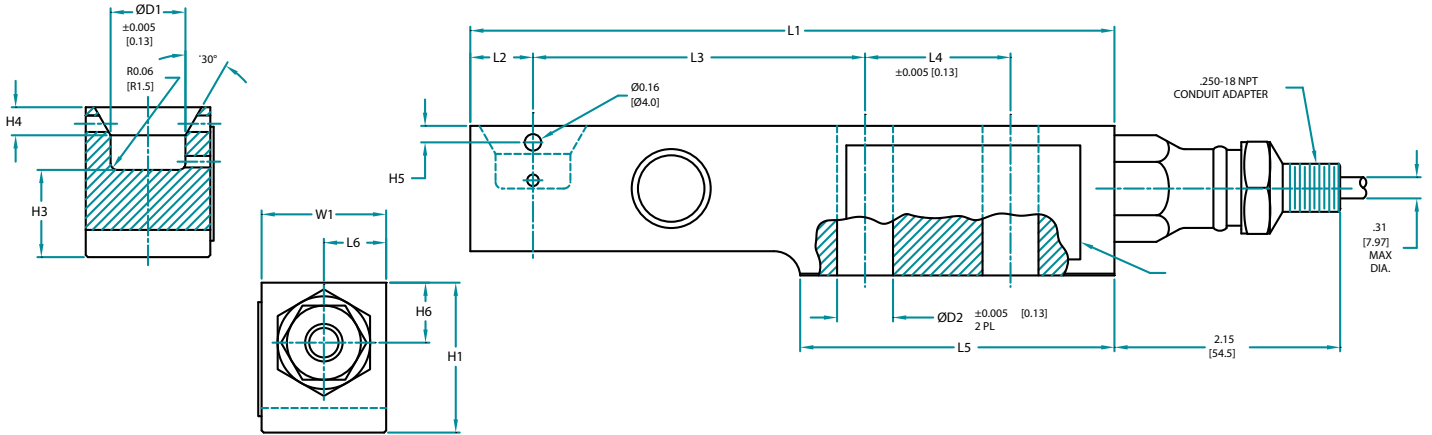

DIMENSIONS- INCHES & [mm]

TOLERANCES: ±0.010 [0.25] UNLESS OTHERWISE STATED

CAPACITY LBS [kN]	L1	L2	L3	L4	L5	L6	H1	H2	H3	H4	H5	H6	W1	ØD1	ØD2	BOLT	TORQUE
1.125K [5]	6.10 [155.0]	0.59 [15.0]	3.15 [80.0]	1.38 [35.0]	2.98 [75.7]	0.59 [15.0]	1.42 [36.0]	0.23 [5.8]	0.83 [21.0]	0.27 [6.9]	0.16 [4.1]	0.59 [15.0]	1.181±0.003 [30.0±.08]	0.709 [18.0]	0.53 [13.5]	.500-20 UNC GRADE 5 [M12 8.8]	65 FT LBS [90Nm]
2.25K [10]	7.48 [190.0]	0.83 [21.0]	4.13 [105.0]	1.57 [39.9]	3.66 [93.0]	0.66 [16.8]	1.93 [49.0]	0.31 [7.9]	1.12 [28.5]	0.23 [5.8]	0.31 [7.9]	0.89 [22.5]	1.693±0.003 [43.0±.08]	0.984 [25.0]	0.85 [21.5]	.750-10 UNC GRADE 5 [M20 8.8]	295 FT LBS [400Nm]
4.5K [20]	9.65 [245.0]	1.19 [30.2]	5.31 [134.9]	1.97 [50.0]	4.72 [120.0]	0.73 [18.5]	2.87 [73.0]	0.50 [12.7]	1.66 [42.2]	0.39 [10.0]	N/A	1.22 [31.0]	2.362±0.005 [60.0±0.13]	1.181 [30.0]	1.06 [27.0]	1.000-8 UNC GRADE 5 [M24 8.8]	515 FT LBS [700Nm]

HI ONEMT Mounts

Model Type/Capacity	Available in	L1	L2	L3	W1	T1	T2	H1	TAP-1	Weld size Xmm	Weld size Ymm	Max Lift off force kN	Tightning Torque for Load cells (Nm)
HIONELP-H-1125, 2.25K & 4.5K	SS, AS, ES	200	152	89	114	12	19	87	M10	5	5	45	90(M12 DIN 8.8)
HIONELP-H-7.5K & 11.25K	SS, AS, ES	256	184	102	148	18	24	111	M16	5	5	75	400(M20 DIN 8.8)
HIONELP-H-22.5K	SS, AS, ES	355	270	130	178	24	29	154	M20	8	8	105	700(M24 DIN 8.8)

PROCEDURE FOR ASSEMBLING THE WEIGH MODULE

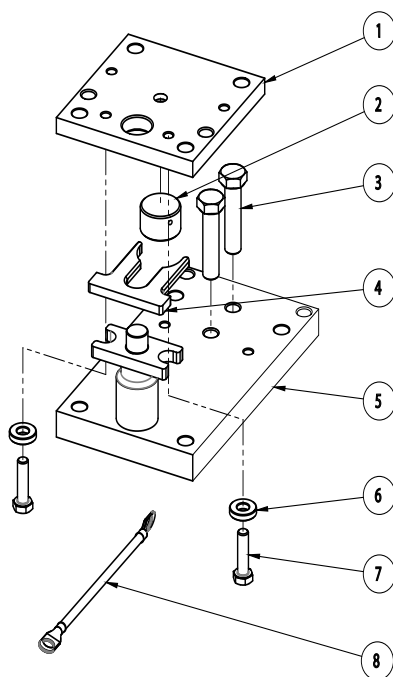

BOLTED MODULE INSTALLATION

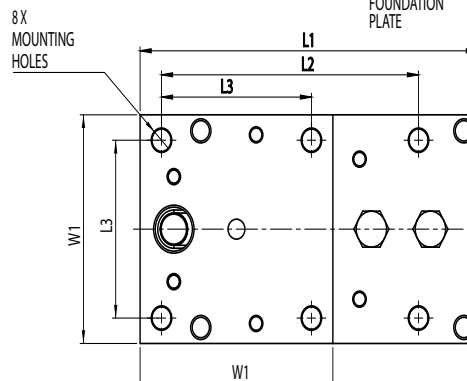
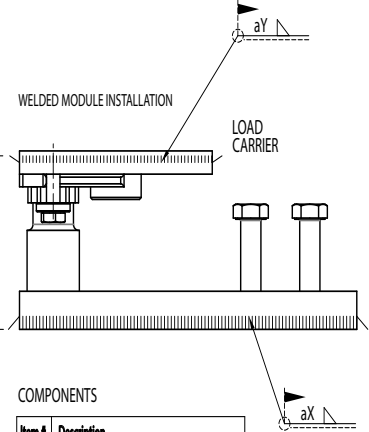
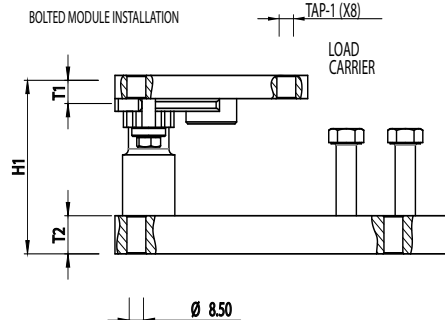

COMPONENTS

Item #	Description
1	Top Plate
2	Load Cup
3	Load Cell Mounting Bolts
4	Shipping & Installation Spacer
5	Base Assembly
6	Washer
7	Lift off Protection Bolts
8	Grounding Strap

OneMount™ and Advantage® Shear Beam Ordering Information



Load Point Assembly (Stainless Steel Sensor and Stainless Steel Mount)					
Capacity Klbs	Capacity kN	Load Point Part #	Load Point Shipping Weight	Sensor Part #	Sensor Shipping Weight
1.125	5	HIONELP-H-1125-SS	12 lb	HISBH04-1125	3.6 lb
2.25	10	HIONELP-H-2.25K-SS	12 lb	HISBH04-2.25K	3.6 lb
4.5	20	HIONELP-H-4.5K-SS	12 lb	HISBH04-4.5K	3.6 lb
7.5	33	HIONELP-H-7.5K-SS	30 lb	HISBH04-7.5K*	5 lb
11.25	50	HIONELP-H-11.25K-SS	30 lb	HISBH04-11.25K	6.65 lb
22.5	100	HIONELP-H-22.5K-SS	60 lb	HISBH04-22.5K*	17 lb

Load Point Assembly (Stainless Steel Sensor and Alloy Steel Mount)					
Capacity Klbs	Capacity kN	Load Point Part #	Load Point Shipping Weight	Sensor Part #	Sensor Shipping Weight
1.125	5	HIONELP-H-1125-AS	12 lb	HISBH04-1125	3.6 lb
2.25	10	HIONELP-H-2.25K-AS	12 lb	HISBH04-2.25K	3.6 lb
4.5	20	HIONELP-H-4.5K-AS	12 lb	HISBH04-4.5K	3.6 lb
7.5	33	HIONELP-H-7.5K-AS	30 lb	HISBH04-7.5K*	5 lb
11.25	50	HIONELP-H-11.25K-AS	30 lb	HISBH04-11.25K	6.65 lb
22.5	100	HIONELP-H-22.5K-AS	60 lb	HISBH04-22.5K*	17 lb

Load Point Assembly (Stainless Sensor and Electropolished Stainless Steel Mount)					
Capacity Klbs	Capacity kN	Load Point Part #	Load Point Shipping Weight	Sensor Part #	Sensor Shipping Weight
1.125	5	HIONELP-H-1125-ES	12 lb	HISBH04-1125	3.6 lb
2.25	10	HIONELP-H-2.25K-ES	12 lb	HISBH04-2.25K	3.6 lb
4.5	20	HIONELP-H-4.5K-ES	12 lb	HISBH04-4.5K	3.6 lb
7.5	33	HIONELP-H-7.5K-ES	30 lb	HISBH04-7.5K*	5 lb
11.25	50	HIONELP-H-11.25K-ES	30 lb	HISBH04-11.25K	6.65 lb
22.5	100	HIONELP-H-22.5K-ES	60 lb	HISBH04-22.5K*	17 lb

Easy Installation Process

1. Align and level the mounts under the vessel without the load cells installed. The mounts can be installed in any orientation, because of a 360° checking mechanism to ensure accuracy and safety.
2. Lower the vessel onto the mounts and weld or bolt the mounts to the foundation and the vessel.
3. Perform any peripheral pipe welding or add any required attachments.
4. Slide the load cell into place and fasten to the bottom plate.
5. Jack the vessel up 1/8" to remove the shipping/installation bracket.
6. Lower the vessel onto the live load point and calibrate using Hardy's C2® electronic calibration.

* **HISBH04-7.5K and HISBH04-22.5K are NOT FM Certified**

Mount Ordering Information					
Sensor Capacity Klbs	Mount Part # Stainless Steel	Mount Part # Alloy Steel	Mount Part # Electropolished Steel	Sensor Part #	
1.125	HIONEMT-4.5KLB-SS	HIONEMT-4.5KLB-AS	HIONEMT-4.5KLB-ES	HISBH04-1125	
2.25				HISBH04-2.25K	
4.5				HISBH04-4.5K	
11.25	HIONEMT-11.25KLB-SS	HIONEMT-11.25KLB-AS	HIONEMT-11.25KLB-ES	HISBH04-11.25K	
22.5	HIONEMT-22.5KLB-SS	HIONEMT-22.5KLB-AS	HIONEMT-22.5KLB-ES	HISBH04-22.5K*	

Optional Dynamic Stabilization Rods		
	Stainless Steel	Alloy Steel
4.5	5504-0074-SS-4.5KLB	5504-0074-AS-4.5KLB
11.25	5504-0074-SS-11.25KLB	5504-0074-AS-11.25KLB
22.5	5504-0074-SS-22.5KLB	5504-0074-AS-22.5KLB

Hardy Process Solutions

10075 Mesa Rim Rd
 San Diego, CA 92121
 tel. +1-858-278-2900
 tel. 800-821-5831
 www.hardysolutions.com
 hardyinfo@hardysolutions.com



All information within is subject to change without notice. Visit our website for latest specifications. OneMount is a trademark of Hardy Process Solutions. WEAVERSAVER, C2, IT, ADVANTAGE and ANY-WEIGH are registered trademarks of Hardy Process Solutions. Encompass is a registered trademark of Rockwell Automation, Inc. All other trademarks or registered trademarks are the property of their respective owners.