



Visualisation; Diagnostics

Easy to Configure

Programming IEC 61131-3

Rapid Installation

PSEN cs3.1a/b

PILZ

THE SPIRIT OF SAFETY

► PSEN sensor technology

This document is the original document.

All rights to this documentation are reserved by Pilz GmbH & Co. KG. Copies may be made for the user's internal purposes. Suggestions and comments for improving this documentation will be gratefully received.

Source code from third-party manufacturers or open source software has been used for some components. The relevant licence information is available on the Internet on the Pilz homepage.

Pilz®, PIT®, PMI®, PNOZ®, Primo®, PSEN®, PSS®, PVIS®, SafetyBUS p®, SafetyEYE®, SafetyNET p®, the spirit of safety® are registered and protected trademarks of Pilz GmbH & Co. KG in some countries.



SD means Secure Digital

Introduction	5
Validity of documentation	5
Using the documentation	5
Definition of symbols	5
Safety	6
Intended use	6
Safety regulations	7
Safety assessment	7
Additional documents that apply	7
Use of qualified personnel	7
Warranty and liability	8
Disposal	8
For your safety	8
Unit features	9
Function description	10
Basic function	10
Block diagram	11
Safety Device Diagnostics	11
Operating distances	12
Lateral and vertical offset	12
Wiring	14
Connection to evaluation devices	15
Single connection	16
Series connection	18
Connection to Pilz evaluation devices	21
Teaching in the actuator	22
Installation	22
General	22
Safety switch	23
Actuator cs1.1 or cs3.1	23
Actuator cs3.1 low profile	24
Align safety switch and actuator	28
Adjustment	28
Operation	29
Dimensions in mm	29
Safety switch	29
Actuator	30

Technical details safety switch	32
Technical details actuator	35
Classification according to ZVEI, CB24I	38
Safety characteristic data	39
Supplementary data	40
Radio approval.....	40
Order reference	40
Safety switch.....	40
Actuator	40
Complete systems	41
Accessories	41
EC declaration of conformity	43

Introduction

Validity of documentation

This documentation is valid for the product PSEN cs3.1a/b from Version 2.0.

This operating manual explains the function and operation, describes the installation and provides guidelines on how to connect the product.

Using the documentation

This document is intended for instruction. Only install and commission the product if you have read and understood this document. The document should be retained for future reference.

Definition of symbols

Information that is particularly important is identified as follows:



DANGER!

This warning must be heeded! It warns of a hazardous situation that poses an immediate threat of serious injury and death and indicates preventive measures that can be taken.



WARNING!

This warning must be heeded! It warns of a hazardous situation that could lead to serious injury and death and indicates preventive measures that can be taken.



CAUTION!

This refers to a hazard that can lead to a less serious or minor injury plus material damage, and also provides information on preventive measures that can be taken.



NOTICE

This describes a situation in which the product or devices could be damaged and also provides information on preventive measures that can be taken. It also highlights areas within the text that are of particular importance.



INFORMATION

This gives advice on applications and provides information on special features.

Safety

Intended use

The safety functions of the safety switch are:

- ▶ Safe shutdown of safety outputs when the actuator is removed beyond the assured release distance s_{ar} or when the actuator is not detected
- ▶ Remain shut down safely after the actuator has been removed

The safety switch meets the requirements in accordance with:

- ▶ EN 60947-5-3: PDDB with one of the approved actuators
- ▶ EN 62061: SIL CL 3
- ▶ EN ISO 13849-1: PL e (Cat. 4)
- ▶ EN ISO 14119: Coding level Low, type 4

The safety switch may only be used with one of the approved actuators.

The safety level PL e (Cat. 4)/SIL CL 3 is only achieved if

- ▶ the safety outputs use 2-channel processing.

The following is deemed improper use in particular

- ▶ Any component, technical or electrical modification to the product,
- ▶ Use of the product outside the areas described in this manual,
- ▶ Use of the product outside the technical details (see [Technical details](#)  32).



NOTICE

EMC-compliant electrical installation

The product is designed for use in an industrial environment. The product may cause interference if installed in other environments. If installed in other environments, measures should be taken to comply with the applicable standards and directives for the respective installation site with regard to interference.

Approved actuators:

- ▶ PSEN cs3.1
- ▶ PSEN cs1.1
- ▶ PSEN cs3.1 low profile glue
- ▶ PSEN cs3.1 low profile screw

Safety regulations

Safety assessment

Before using a device it is necessary to perform a safety assessment in accordance with the Machinery Directive.

Functional safety is guaranteed for the product as a single component. However, this does not guarantee the functional safety of the overall plant/machine. In order to achieve the required safety level for the overall plant/machine, define the safety requirements for the plant/machine and then define how these must be implemented from a technical and organisational standpoint.

Additional documents that apply

Please read and take note of the following documents.

Only for use of the Safety Device Diagnostics (SDD):

- ▶ Operating manual for the fieldbus module, for example SDD ES ETH or SDD ES PROFIBUS
- ▶ System description "Safety Device Diagnostics"

For the use of passive junctions:

- ▶ Operating manual of a passive junction, for example:
 - PSEN ix2 F4 code
 - PSEN ix2 F8 code
 - PDP67 F 4 code

You will need to be conversant with the information in these documents in order to fully understand this operating manual.

Use of qualified personnel

The products may only be assembled, installed, programmed, commissioned, operated, maintained and decommissioned by competent persons.

A competent person is a qualified and knowledgeable person who, because of their training, experience and current professional activity, has the specialist knowledge required. To be able to inspect, assess and operate devices, systems and machines, the person has to be informed of the state of the art and the applicable national, European and international laws, directives and standards.

It is the company's responsibility only to employ personnel who

- ▶ Are familiar with the basic regulations concerning health and safety / accident prevention,
- ▶ Have read and understood the information provided in the section entitled Safety
- ▶ Have a good knowledge of the generic and specialist standards applicable to the specific application.

Warranty and liability

All claims to warranty and liability will be rendered invalid if

- ▶ The product was used contrary to the purpose for which it is intended,
- ▶ Damage can be attributed to not having followed the guidelines in the manual,
- ▶ Operating personnel are not suitably qualified,
- ▶ Any type of modification has been made (e.g. exchanging components on the PCB boards, soldering work etc.).

Disposal

- ▶ In safety-related applications, please comply with the mission time T_M in the safety-related characteristic data.
- ▶ When decommissioning, please comply with local regulations regarding the disposal of electronic devices (e.g. Electrical and Electronic Equipment Act).

For your safety**WARNING!****Loss of safety function due to manipulation of the interlocking device**

Manipulation of the interlocking device may lead to serious injury and death.

- You should prevent any possibility of the interlocking device being manipulated through the use of a spare actuator.
- Keep the substitute actuator in a safe place and protect it from unauthorised access.
- If spare actuators are used, these must be installed as described in [Installation](#) [ 22].
- If the original actuators are replaced with substitute actuators, the original actuators must be destroyed before disposal.

Unit features

- ▶ Transponder technology for presence detection
- ▶ Pilz coding type: Coded
- ▶ Dual-channel operation
- ▶ 2 safety inputs for series connection of multiple safety switches
- ▶ 2 safety outputs
- ▶ Safety Device Diagnostics (SDD)
 - Safety Device Diagnostics can be used to poll sensor information, to perform actions and to read configuration parameters
 - Manipulation protection in accordance with ISO 14119 is possible by verifying the short name of the actuator through the controller via SDD communication
- ▶ Diagnostic input for Y1 for Safety Device Diagnostics (SDD)
- ▶ Signal output/diagnostic output Y32 for Safety Device Diagnostics
- ▶ LED display for:
 - State of the actuator
 - State of the inputs
 - Supply voltage/fault
- ▶ 1 direction of actuation
- ▶ Connection types:
 - PSEN cs3.1a: Cable, 5 m
 - PSEN cs3.1b: Cable, 10 m

Function description

Basic function

The safety outputs may have a high or low signal, depending on the position of the actuator and the signal status of the inputs.

In a safe condition the safety outputs are in the OFF state.

Electrical states of the inputs and outputs (when safety switch is ready for operation: Power/Fault LED is green):

Actuator within the response range	Safety input S11	Safety input S21	Safety output 12	Safety output 22	Signal output Y32 (without use of the SDD)
Yes	High	High	High	High	High
Yes	Low	Low	Low	Low	High
No	x	x	Low	Low	Low
Yes	High	Low	High	Low	High
Yes	Low	High	Low	High	High

x: High or low signal

Plausibility monitoring for safety inputs S11 and S21

- ▶ If one safety input switches from high to low, while the other safety input remains high, an unequal status is displayed: **Input LED flashes yellow**
- ▶ If this safety input switches back from low to high, while the other safety input remains high, a plausibility error is displayed and a partial operation lock is triggered: **Input LED flashes yellow**

A switch to a high signal will only lead to normal safety switch operation if both inputs had a low signal. From this moment on, the switch to high may occur (partial operation lock see [Error display \[📖 29\]](#)).

▶ Diagnostic input Y1

If a fieldbus module of the SDD is used, the diagnostic input Y1 is automatically activated and data is read.

If no fieldbus module of the SDD is used, the diagnostic input Y1 is not used.

▶ Signal output/diagnostic output Y32

The status of the actuator is output. If a fieldbus module of the SDD is used, the signal output/diagnostic output for the writing of data is activated.

Block diagram

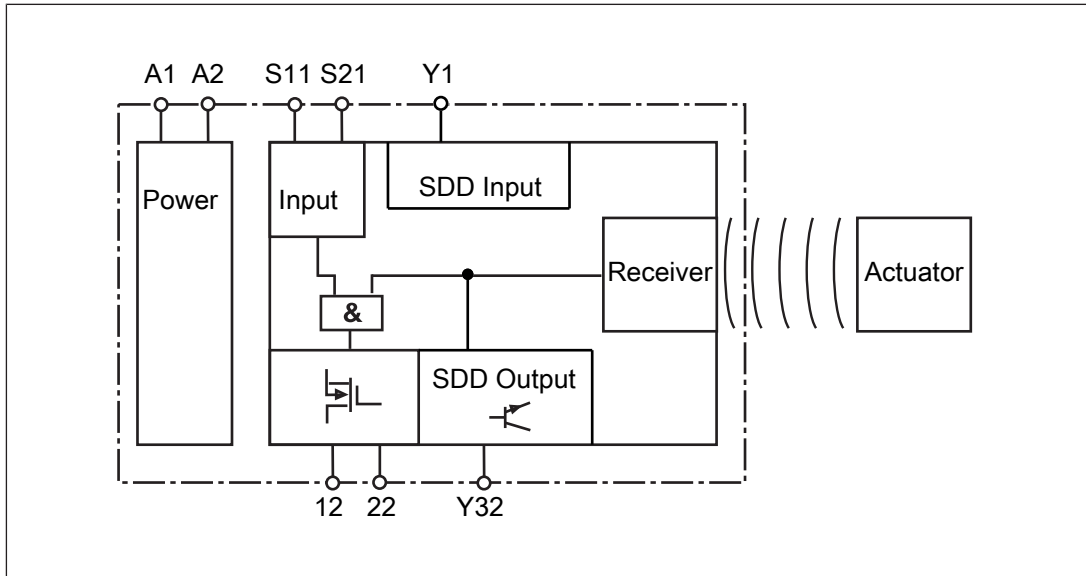

Safety Device Diagnostics

Safety Device Diagnostics is an option that can be selected independently of the safety-related wiring.

When using the Safety Device Diagnostics, up to 16 sensors connected in series can be connected as a subscriber to a fieldbus module.

The communication of the sensors with the fieldbus module is automatically built up again with each new supply of the supply voltage. As a result, a sensor can be exchanged, e.g. when servicing, without the need for special measures.

An exchange can be detected via the fieldbus module e.g. through the serial number.

- ▶ With Safety Device Diagnostics there are the following diagnostic options for the fieldbus module:
 - Poll information of the sensors (examples: what sensor in the series has switched, at what point could there be an open circuit in the series connection)
 - Read configuration parameters of the sensor (examples: Number of teach-in processes remaining, serial number of the sensor)
 - Perform actions (example: poll updated actuator name)

The results of the sensor diagnostics can be checked already during the installation phase via the display in the fieldbus module, without the need to connect the fieldbus module to the network.

- ▶ With Safety Device Diagnostics there are the following diagnostic options for the fieldbus module for simple wiring:
 - Information is passed on via the fieldbus module directly to the network
 - Mappings of the signal outputs to the sensor are automated by the SDD.

This prevents wiring errors and an expansion or reduction of the sensors is possible without the need to change existing wiring.

- Wiring in accordance with IP20: Rapid installation in the control cabinet is enabled.
- Wiring in accordance with IP67: Various passive junctions can be used (see [Order references for accessories \[41\]](#)) to connect several sensors with only one cable from the field in the control cabinet.

Further information on Safety Device Diagnostics can be found in [Additional documents that apply \[7\]](#).

Operating distances

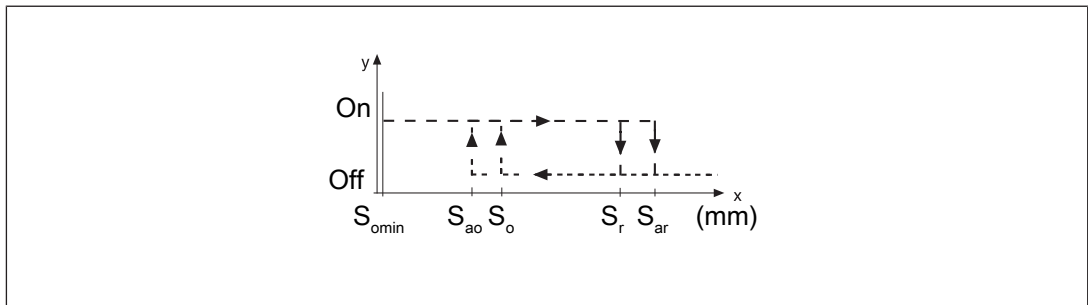

Legend

- S_{ao} Assured operating distance
- S_{omin} Min. operating distance
- S_{ar} Assured release distance

The offset-independent values for the switching distances are included in the [Technical details \[32\]](#).

Lateral and vertical offset

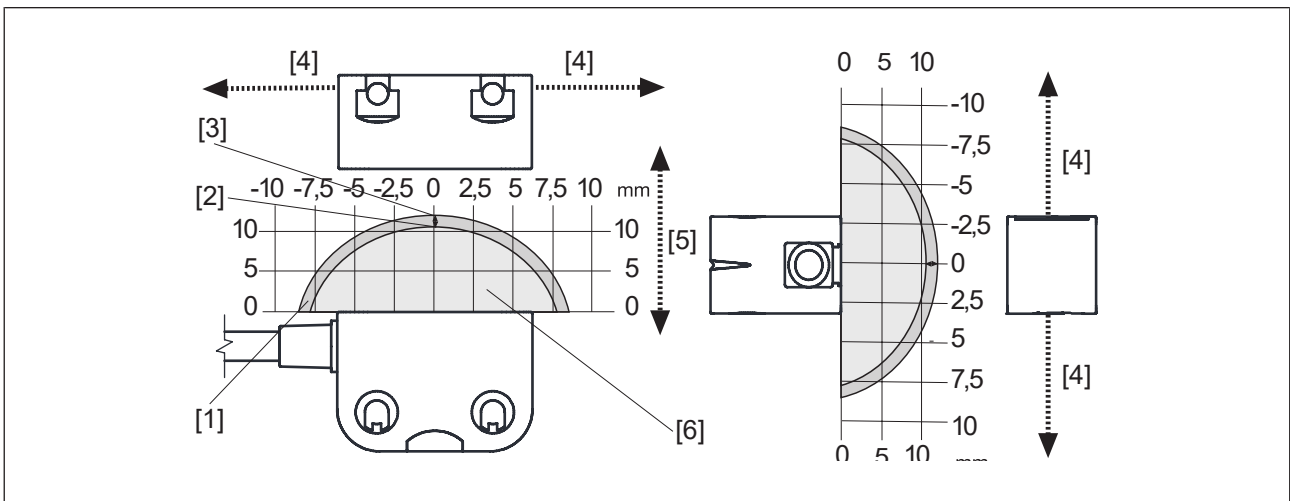

Fig.: Safety switches PSEN cs3.1a/b with actuator PSEN cs3.1

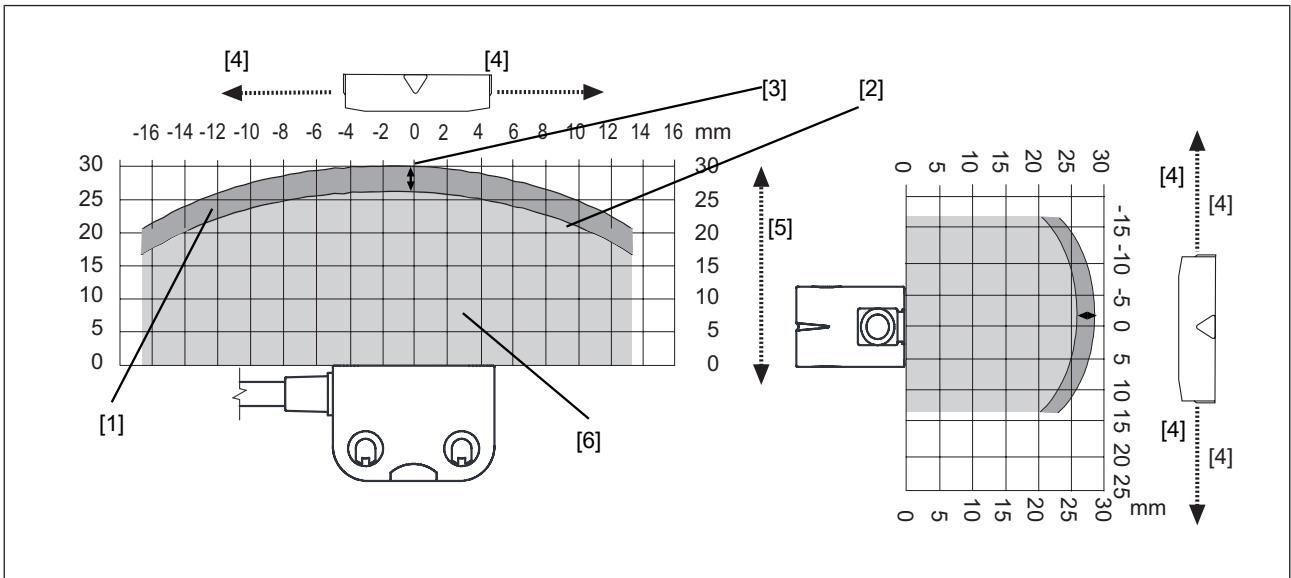

Fig.: Safety switches PSEN cs3.1a/b with actuator PSEN cs1.1

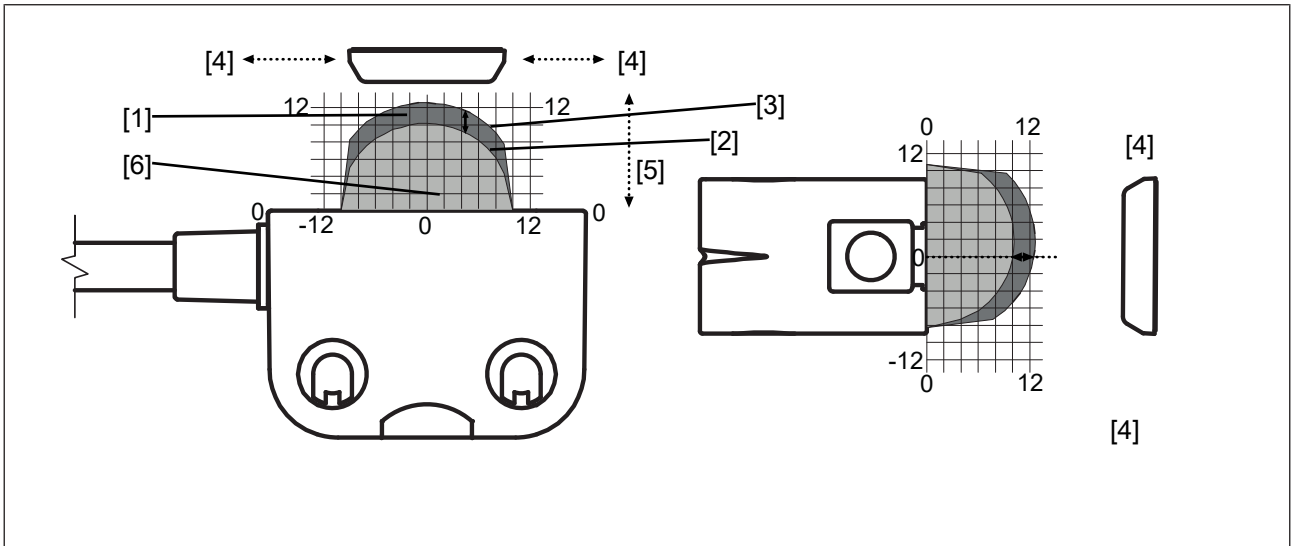

Fig.: Safety switches PSEN cs3.1a/b with actuator PSEN cs3.1 low profile glue or PSEN cs3.1 low profile screw

Legend

- [1] Hysteresis
- [2] Typical operating distance S_o
- [3] Typical release distance S_r
- [4] Offset in mm
- [5] Operating distance in mm
- [6] Response range

Wiring

- ▶ Information given in the [Technical details \[32\]](#) must be followed.
- ▶ Switch off the supply voltage before disconnecting the safety switch from the supply voltage.
- ▶ Make sure that when connecting or separating the connector the pollution degree 1 or 2 is maintained.
- ▶ The max. cable length l_{\max} in the input circuit is calculated from
 - the max. cable capacitance at the safety outputs (see [Technical data \[32\]](#)).
 - the minimum permitted supply voltage at the safety switch (19.2 V).
- ▶ The power supply must meet the regulations for extra low voltages with protective electrical separation (SELV, PELV).
- ▶ The inputs and outputs of the safety switch must have a protective separation to voltages over 60 VDC.



INFORMATION

Only use safety relays with a 24 VDC supply voltage. Safety relays with a wide-range power supply or in AC device versions have internal potential isolation and are not suitable as evaluation devices.

- ▶ The supply voltage to the safety switch must be protected with a 2 A to 4 A quick-acting fuse.
- ▶ Ensure the wiring and EMC requirements of EN 60204-1 are met.
- ▶ When connecting in series, consider the requirements of manipulation protection and the protection against bypassing or from overriding the safety switch (EN ISO 14119).
- ▶ When the safety inputs of the safety switch are controlled by an upstream device, and they are not wired with 24 V,
 - They must be monitored for shorts across contacts (e.g. by PSEN cs, PSEN ml, PSEN sg or PSEN sl) **or**
 - The faults at the safety inputs that can occur by shorts across contact will have to be excluded by suitable measures (e.g. wiring in accordance with EN 602041).

Pin assignment for cable

PIN	Connection designation	Function	Wire colour
1	S21	Input, channel 2	white
2	A1	+24 VUB	brown
3	12	Output, channel1	green
4	22	Output, channel2	yellow
5	Y32	Signal output/diagnostic output	grey
6	S11	Input, channel 1	pink
7	A2	0 V UB	blue
8	Y1	Diagnostics input	red

The wire colour also applies for the cable available from Pilz as an accessory.

Connection to evaluation devices

Make sure that the selected evaluation device has the following property:

- ▶ OSSD signals are evaluated through 2 channels with plausibility monitoring

Please note:

- ▶ Information given in the [Technical details \[32\]](#) must be followed.
- ▶ The use of Safety Device Diagnostics is described in the System Description "Safety Device Diagnostics".



CAUTION!

Do not connect the signal output to 0 V!

If the signal output Y32 is connected to 0 V, the safety switch may be damaged as a result. Connect the signal output Y32 to a consumer, e.g. to the input on a control system, or leave the signal output unconnected. Also note the max. current (see [Technical details \[32\]](#)).

Single connection

Connection diagram, single connection without SDD

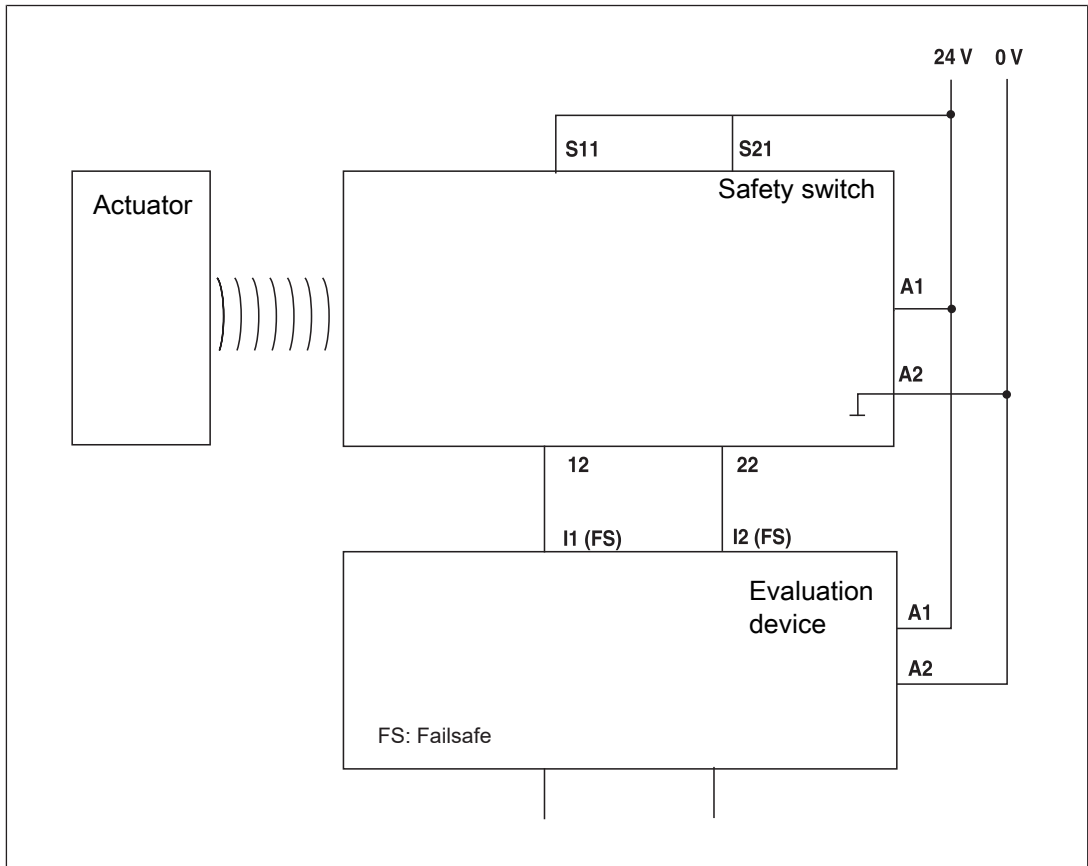

Connection diagram, single connection with SDD

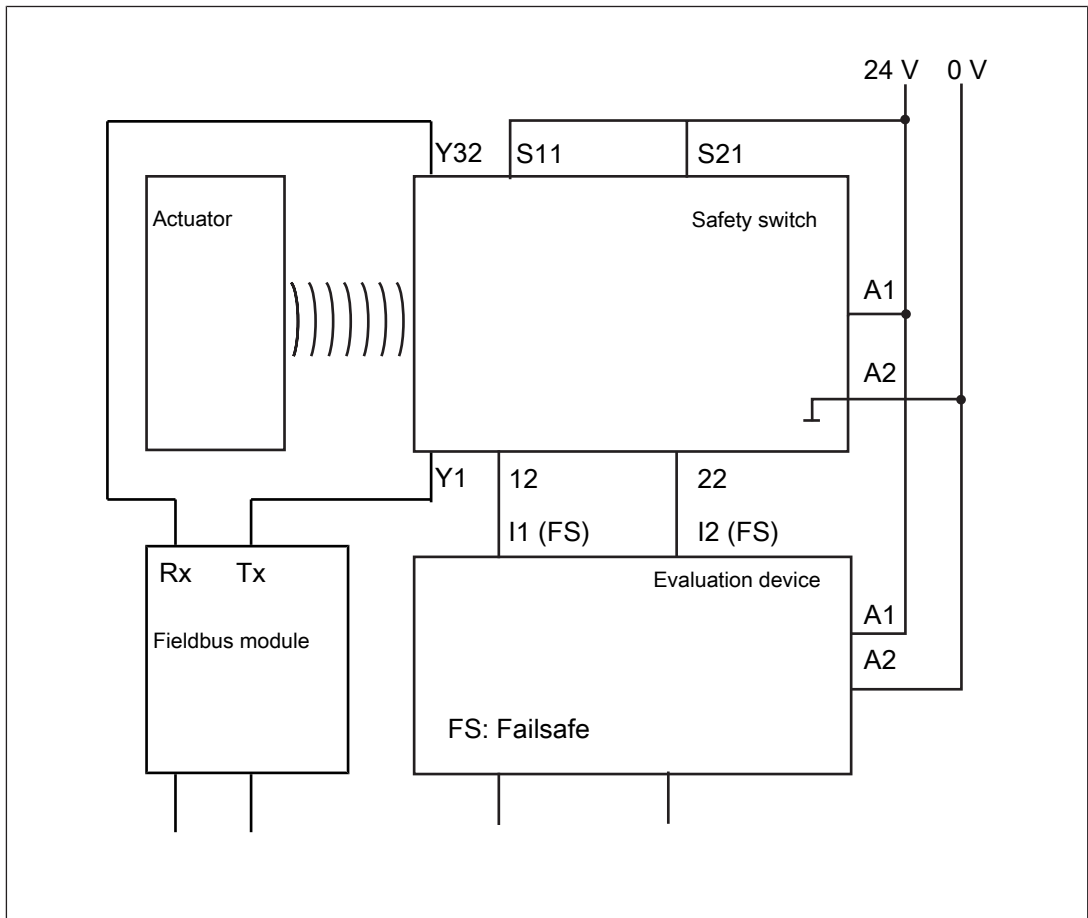

Series connection

The safety sensors PSENcode are also suitable for series connection with other sensors.

Maximum number of PSENcode sensors switched in series connections for SIL CL 3 using SDD

- ▶ PSENcode compact design (PSEN cs3 – cs4, 8-pin): 12

When using other SDD-compatible sensors, the number must be recalculated.

In practice, the maximum possible number will be limited by the following parameters, among others:

- ▶ The required SIL level (e.g. SIL CL 3),
- ▶ the required performance level (e.g. PL e (Cat. 4)),
- ▶ the maximum delay or risk time permitted by the application.

Ensure there is sufficient supply voltage, taking inrush currents and fusing into consideration.



CAUTION!

Extension of delay-on de-energisation

When several (n) devices are connected in series, the delay-on de-energisation time adds with the number of interconnected safety switches.

The max. delay-on de-energisation is made up of the

risk time (see [Technical details](#) [ 32])

+ (n-1) x max. delay-on de-energisation of the inputs

+ max. delay-on de-energisation of the evaluation device

- ▶ When making series connections using SDD, only use the following passive junctions.
 - PSEN ix2 F4 code
 - PSEN ix2 F8 code
 - PSEN Y junction M8-M12/M12 PIGTAIL
 - PSEN Y junction M12-M12/M12 PIGTAIL
 - PSEN Y junction M12 SENSOR
 - PSEN Y junction M12 cable channel
 - PSEN Y junction M8 SENSOR
 - PSEN Y junction M8 cable channel

Connection diagram, series connection without SDD

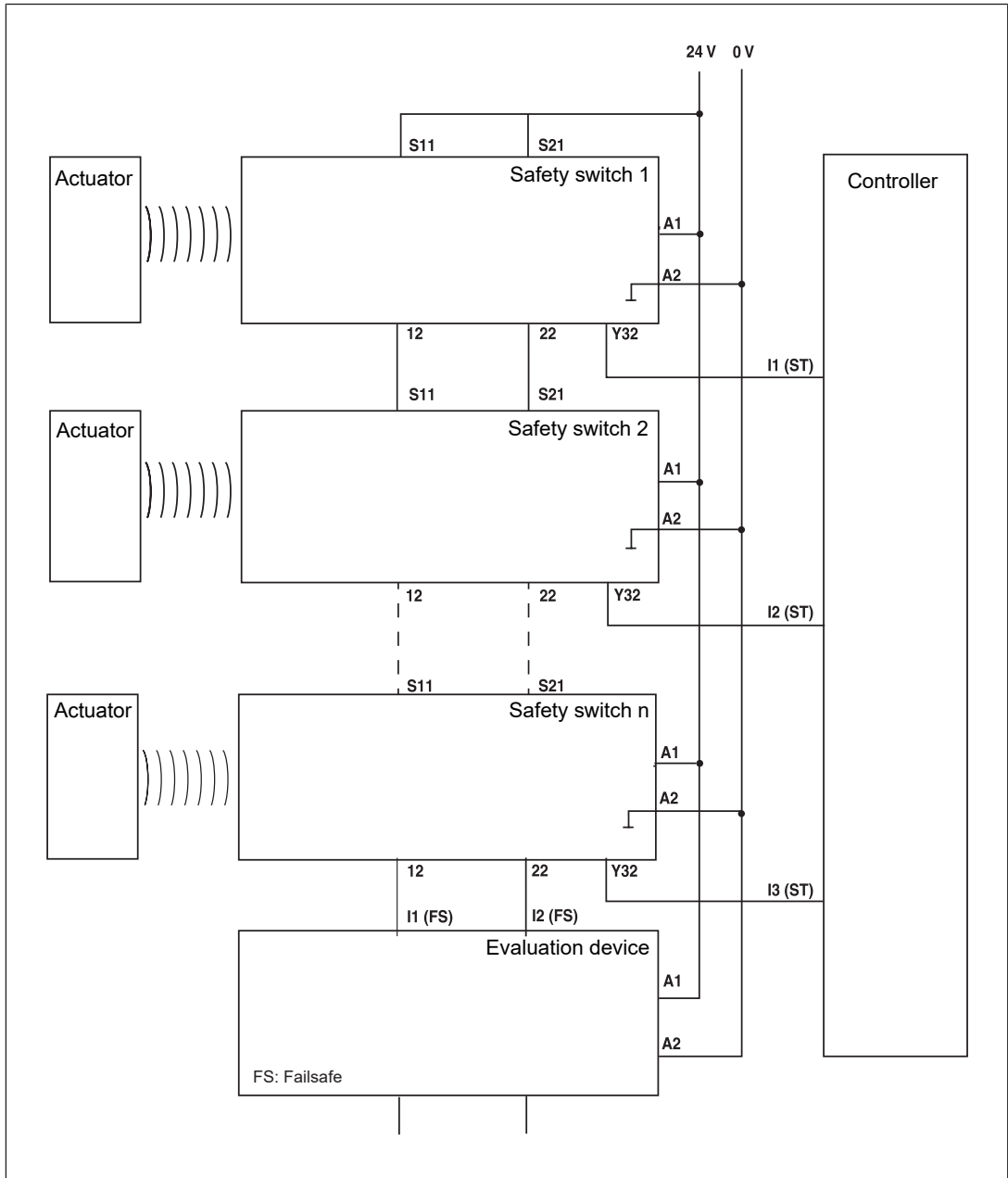

Connection diagram, series connection with SDD

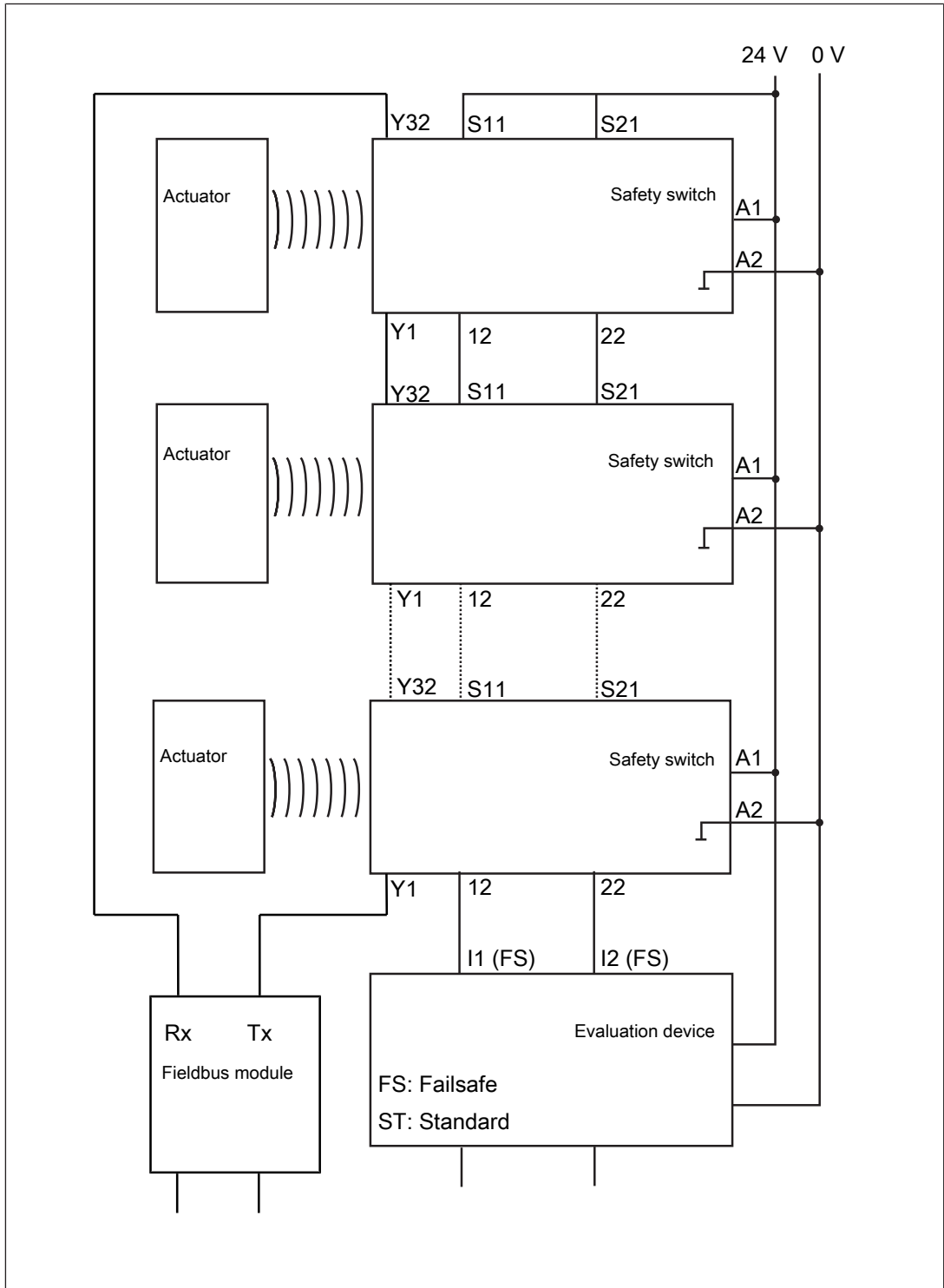

Connection to Pilz evaluation devices

The safety switch PSEN cs3.1a/b can be connected to Pilz evaluation devices, for example.

Suitable Pilz evaluation devices are, for example:

- ▶ PNOZelog for safety gate monitoring
- ▶ PNOZpower for safety gate monitoring
- ▶ PNOZsigma for safety gate monitoring
- ▶ PNOZ X for safety gate monitoring
- ▶ PNOZmulti for safety gate monitoring
Configure the safety switch in the PNOZmulti Configurator with switch type 3.
- ▶ PSS for safety gate monitoring with standard function block SB064, SB066 or FS_Safety Gate

The correct connection to the respective evaluation device is described in the operating manual for the evaluation device. Make sure that the connection is made in accordance with the specifications in the operating manual for the selected evaluation device.

The connections to two evaluation devices are shown on the following pages, by way of example:

- ▶ PNOZ s3 and
- ▶ PNOZmulti

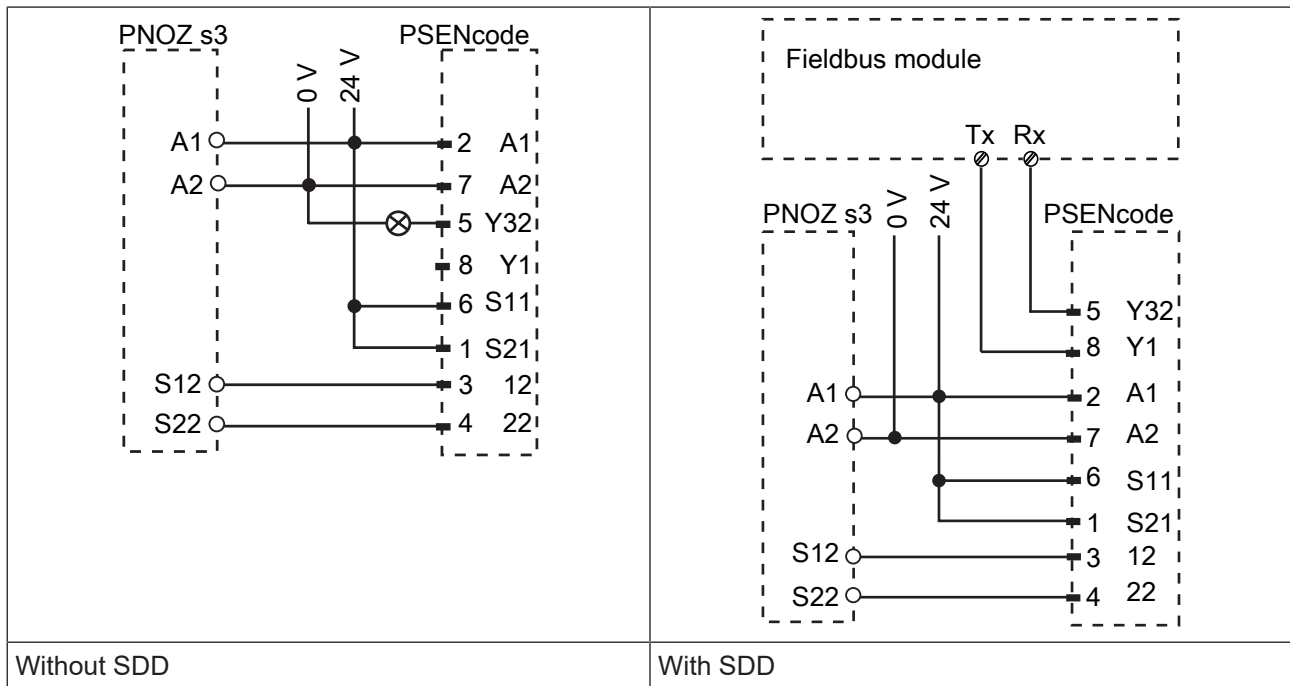

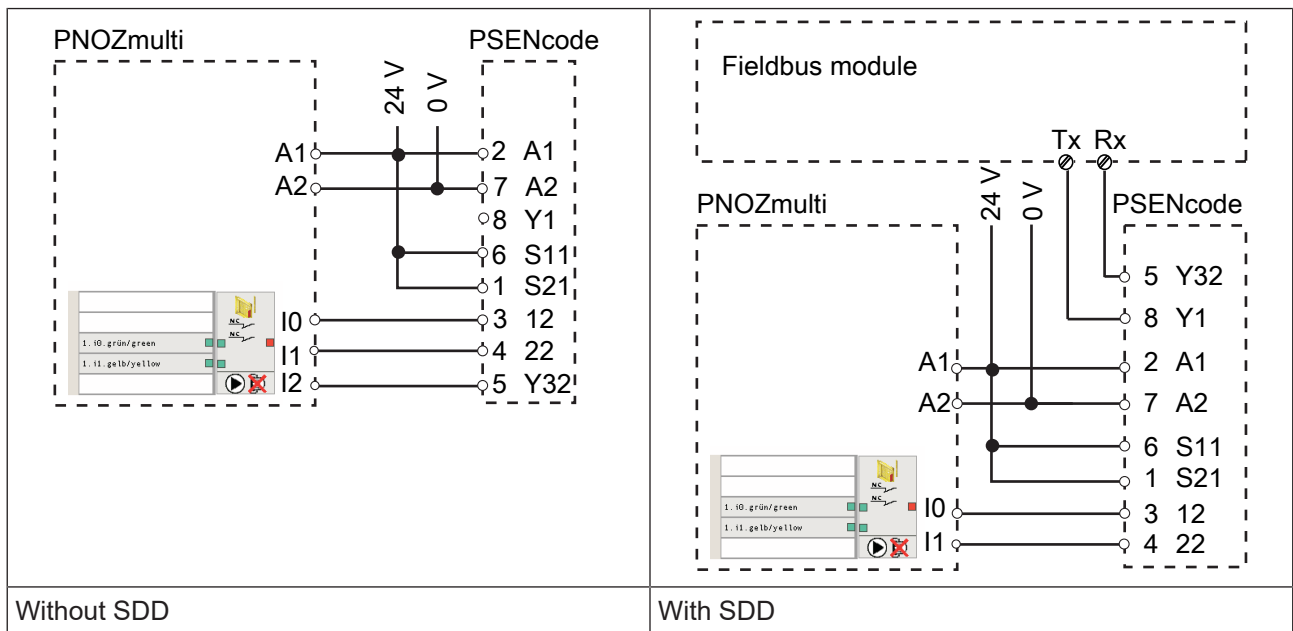

Teaching in the actuator

Any approved Pilz actuator (see Intended use) is detected as soon as it is brought into the response range.

Installation

General



CAUTION!

Potential loss of safety function due to changed device properties

The unit's properties may be affected if installed in an environment containing electrically or magnetically conductive material.

- Please check the operating distances and the assured release distance.

- ▶ The safety switch and actuator should be installed opposite each other in parallel.
- ▶ Torque setting: Please note the information provided under [Technical details \[32\]](#).
- ▶ The distance between two safety switches must be maintained (see [Technical details \[32\]](#)).
- ▶ Make sure that the safety switch and actuator cannot be used as an end stop.
- ▶ Please note the installation measures in accordance with EN ISO 14119 for a safety switch design 4 and with level of coding Low.
- ▶ Please note the permitted bending radii for the cable (see [Technical details \[32\]](#)), to avoid excessive force on the individual strands.

- ▶ Make sure that the bend protection is not damaged. Such damage can cause the whole product to fail.
- ▶ For simpler installation, the mounting brackets (see [Order reference for Accessories](#) [📖 41]) can be used.

Safety switch

- ▶ Safety switches should only be secured using M4 screws with a flat head (e.g. M4 cheese-head or pan head screws).

Procedure:

1. Provide the mounting surface with two drill holes for fastening the safety switch (see [Dimensions in mm](#) [📖 29]).
2. Use two screws to fix the safety switch in place. Do not fully tighten the 2nd screw on the safety switch.

Actuator cs1.1 or cs3.1

Procedure actuator PSEN cs3.1:

1. Only use M4 screws with a flat head (e.g. M4 cheese-head or pan head screws).
Provide the mounting surface with two drill holes for the screw connection of the actuator (see [Dimensions in mm](#) [📖 29]).
2. Attach the screws for the actuator, leaving a distance of 3 ... 6 mm between the screw head and plate.
3. Slide the actuator on to the screws. The arrows on the labelled surfaces of the safety switch and actuator must face each other. Align the actuator and tighten the screws.
4. The actuator should be protected from unauthorised removal and from contamination. Close the mounting holes using the seals provided. The use of seals should be regarded as equivalent to using permanent fastenings in accordance with EN ISO 14119.

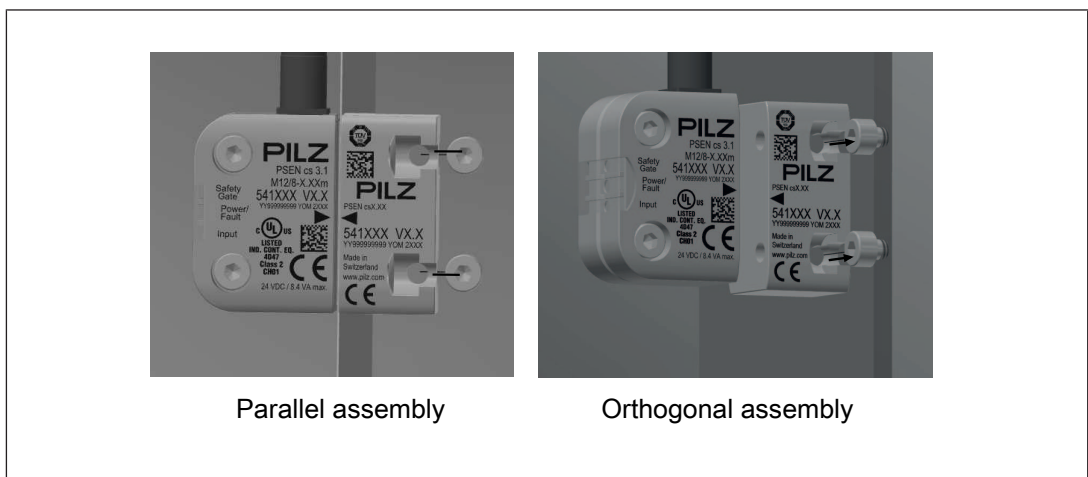

Procedure actuator PSEN cs1.1:

1. Use permanently secured M5 safety screws with a flat head (e.g. M5 cheese-head or pan head screws).

Provide the mounting surface with two drill holes for the screw connection of the actuator (see [Dimensions in mm](#) [ 29]).

2. Use two screws to fix the actuator in place. Align the actuator and tighten the screws.

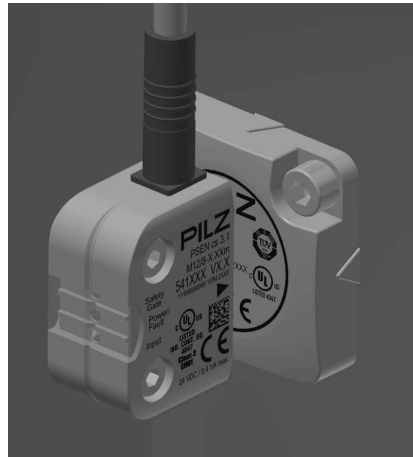
**Actuator cs3.1 low profile****WARNING!****Loss of the manipulation protection by inadequate environmental conditions**

The loss of the manipulation protection can allow manipulation of the interlocking device and it may lead to serious injury or death.

- Make sure that the actuator has no direct or repetitive contact with materials such as methyl ethyl ketone (MEK), petrol or isopropanol.

- ▶ The actuator is secured against unauthorised removal, and against contamination by the sealing. The seal should be regarded as equivalent to using permanent fastenings in accordance with EN ISO 14119.
- ▶ By removing the actuator, the actuator will be destroyed.
- ▶ The actuator's adhesive force on the materials aluminium, stainless steel, polycarbonate and glass was checked. For deviating surface materials check the adhesive force on the surface.
- ▶ After a cure time of 24 hours, 90 % of the final adhesive force are achieved. The hardening must take place at min. 20 °C. With lower temperatures the cure time is clearly extended.
- ▶ No continuous force must affect the actuator.

Procedure actuator PSEN cs3.1 low profile glue

1. To seal the low profile actuators correctly, it is necessary to prepare the surface to which the actuator is to be attached.

The surface must be clean, dry and free of grease.

Wipe off any solved grease and contaminations with a new, dry paper cloth.

Clean the surface with 70% isopropanol. Use lint-free paper cloths and change the paper cloths frequently.

The adhesive surface is clean when the paper remains clean.

The cleaned surfaces must be sealed immediately to prevent any new contamination by dust and fingerprints.

2. Remove the protective foil from the assembly aid and fix it to the sensing area of the safety switch.
3. Place the actuator into the assembly aid so that the actuator's covered adhesive surface is on the surface.

Make sure that the actuator's centre is on the same level as the orientation arrows of the sensor and in the centre of the sensor.

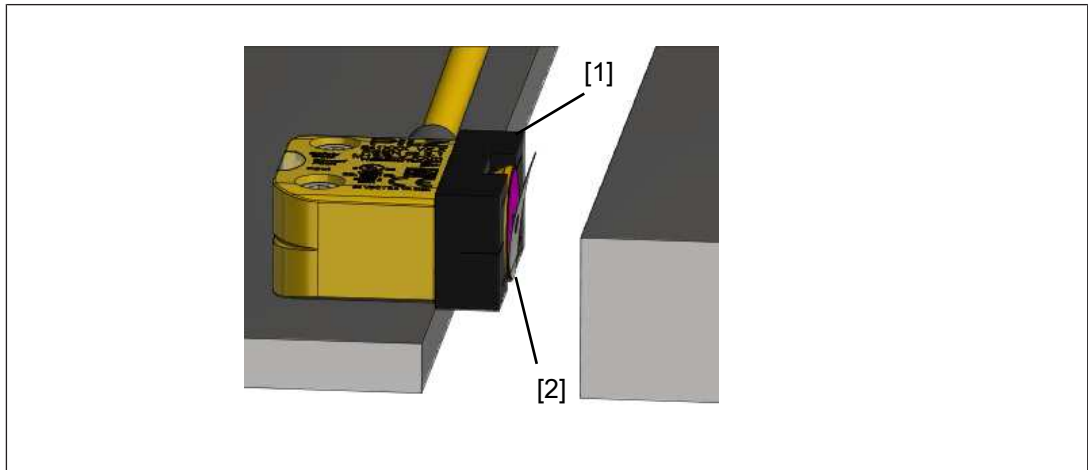

Fig.: Safety switch with assembly aid and low profile actuator

Legend

[1] Assembly aid for low profile actuator

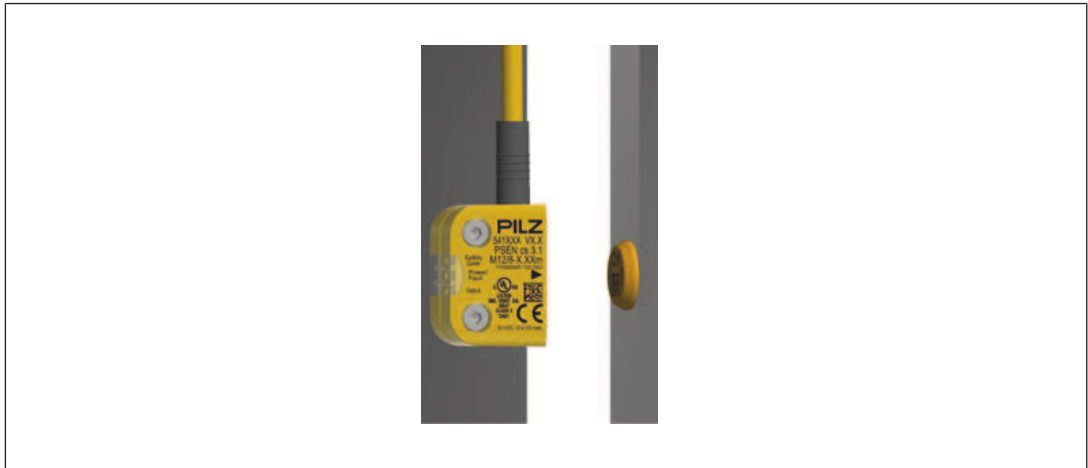

[2] low profile actuator

4. Remove the protective foil from the adhesive foil of the actuator.
Do not touch the adhesive foil after removing the protective foil!
5. Close the safety gate carefully and then press the actuator to the adhesive position.
6. Press on the actuator for at least 3 seconds with approx. 50 N.
After this time, an adhesive force of approx. 50 % is achieved. The full adhesive force is achieved after 72 hours at an ambient temperature of at least 20 °C.



7. Check the adhesive force of the glue after 10 minutes.
The actuator must no move when pressed sideways.
8. Remove the assembly aid from the safety switch and clean the sensing area of the safety switch.

Procedure actuator PSEN cs3.1 low profile screw

1. Provide the mounting surface with a drill hole for an additional screw connection of the actuator (see [Dimensions in mm](#)  29]).
2. To seal the low profile actuators correctly, it is necessary to prepare the surface to which the actuator is to be attached.
The surface must be clean, dry and free of grease.
Wipe off any solved grease and contaminations with a new, dry paper cloth.
Clean the surface with 70% isopropanol. Use lint-free paper cloths and change the paper cloths frequently.
The adhesive surface is clean when the paper remains clean.
The cleaned surfaces must be sealed immediately to prevent any new contamination by dust and fingerprints.
3. Remove the protective foil from the assembly aid and fix it to the sensing area of the safety switch.
4. Place the actuator into the assembly aid so that the actuator's covered adhesive surface is on the surface.
Make sure that the actuator's centre is on the same level as the orientation arrows of the sensor and in the centre of the sensor.
5. Remove the protective foil from the adhesive foil of the actuator.
Do not touch the adhesive foil after removing the protective foil!
6. Insert the screw into the actuator's hole and position the screw at the hole on the mounting surface.
To screw on the actuator, use the supplied plastic M3 countersunk screw.
When using a screw mad from metal the operating distance change, please note the [Warning](#)  22].

7. Press on the actuator for at least 3 seconds with approx. 50 N.

After this time, an adhesive force of approx. 50 % is achieved. The full adhesive force is achieved after 72 hours at an ambient temperature of at least 20 °C.

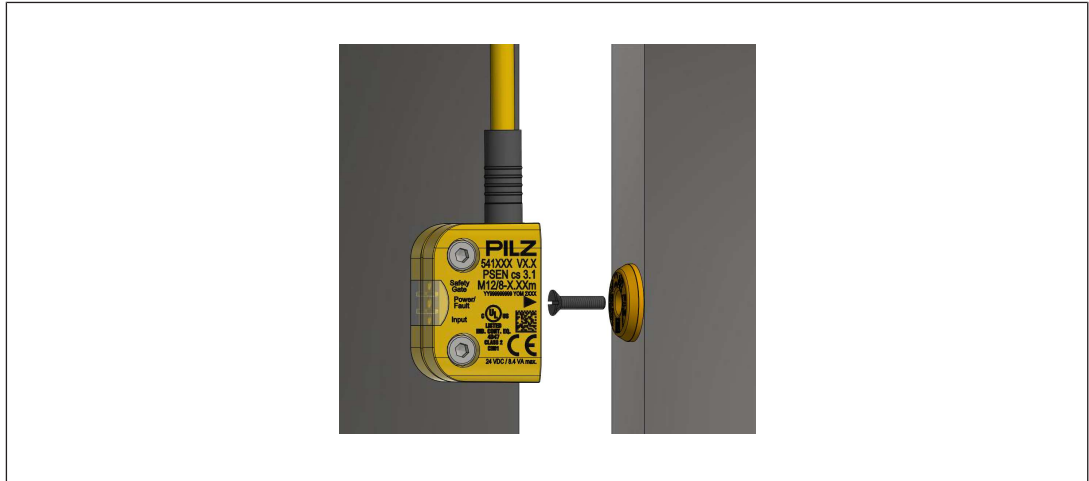

8. Check the adhesive force of the glue after 10 minutes.
The actuator must no move when pressed sideways.
9. Tighten the M3 plastic screw to 0,8 Nm.

Align safety switch and actuator

Procedure:

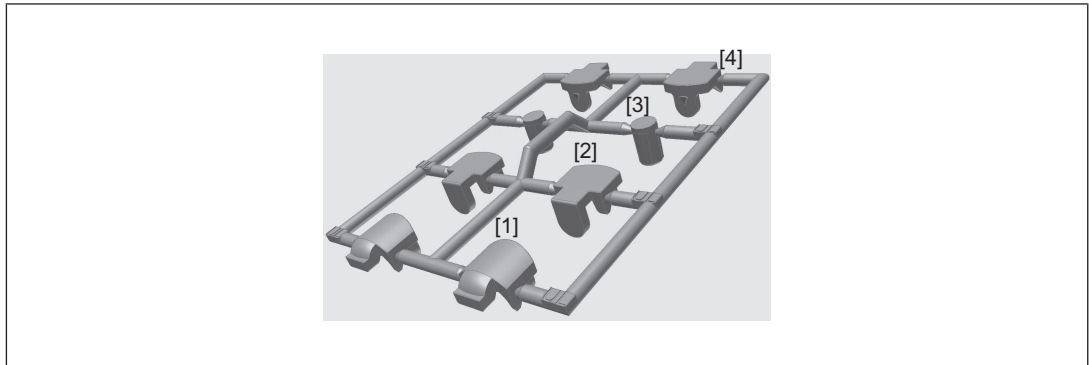

1. Align the safety switch and tighten the screws.
2. Actuator PSEN cs3.1
Align the actuator and tighten the screws.
3. Close the mounting holes using the seals provided (see diagram).
Use the seals [1] for UL approval or [4] without UL approval.



Legend

- [1] Side seal with UL approval
 - [2] Bottom seal
 - [3] Top seal, sensing side
 - [4] Side seal without UL approval
4. Use the seals to close the mounting holes on the sensing face of the safety switch (see diagram, [3]).
 5. If necessary, use the seals to close the unused mounting holes on the actuator (see diagram, [2]).

Adjustment

- ▶ The stated operating distances (see [Technical details](#)  32) only apply when the safety switch and actuator are installed facing each other in parallel. Operating distances may deviate if other arrangements are used.
- ▶ Note the maximum permitted lateral and vertical offset (see [Operating distances](#)  12) and [Lateral and vertical offset](#)  12).

Operation



NOTICE

The safety function should be checked after initial commissioning and each time the plant/machine is changed. The safety functions may only be checked by qualified personnel.

Status indicators:

- ▶ "Power/Fault" LED lights up green: The unit is ready for operation
- ▶ "Safety Gate" LED lights up yellow: Actuator is within the response range
- ▶ "Input" LED lights up yellow: There is a high signal at both inputs

Fault indicator:

- ▶ "Input" LED lights up yellow: the signal switches from high to low at one input, while a high signal remains on the other input (partial operation).
Remedy: Open both channels of the input circuit.
- ▶ "Power/Fault" LED lights up red: Error message
Remedy: Rectify fault and interrupt power supply.

Dimensions in mm

Safety switch

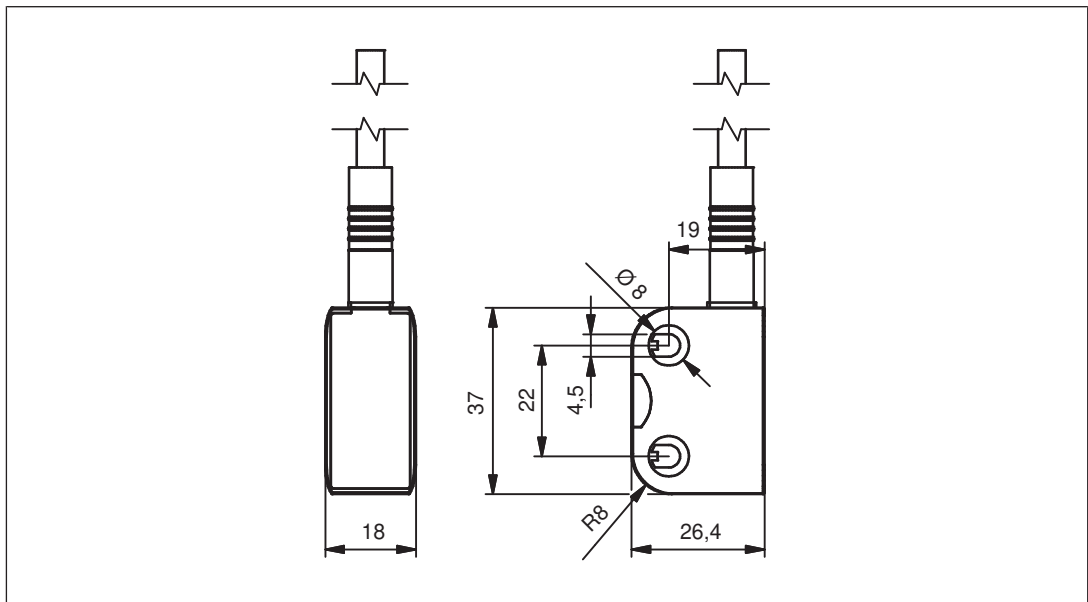

Actuator

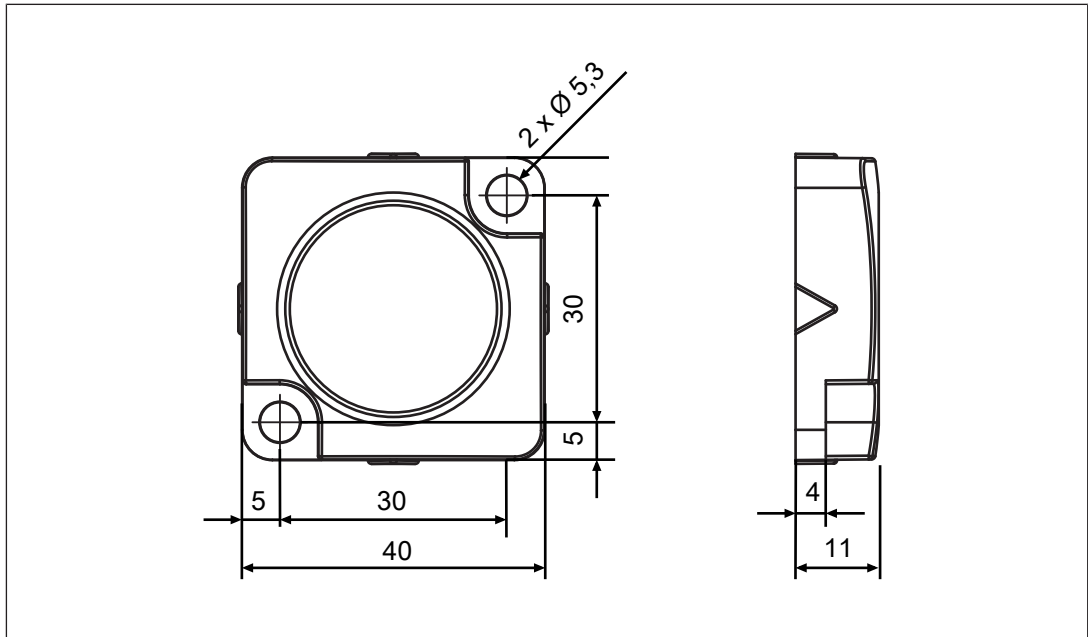

Fig.: Actuator PSEN cs1.1

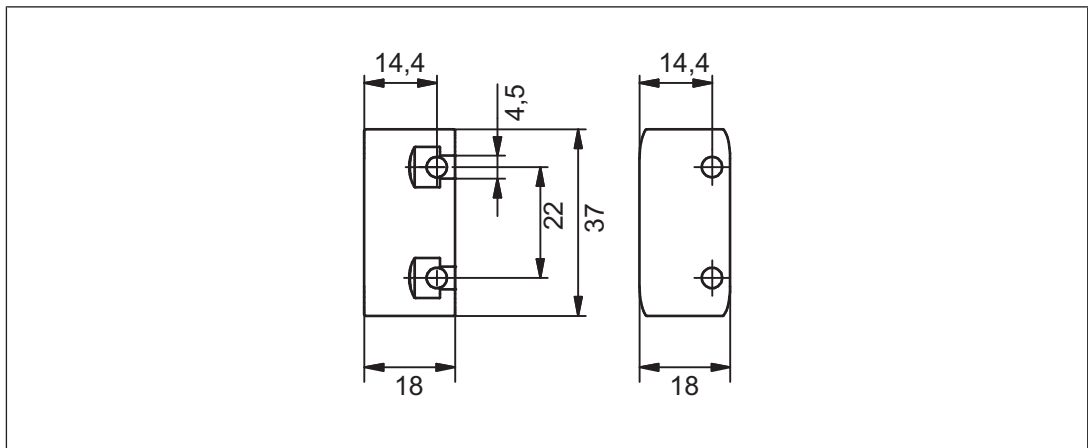
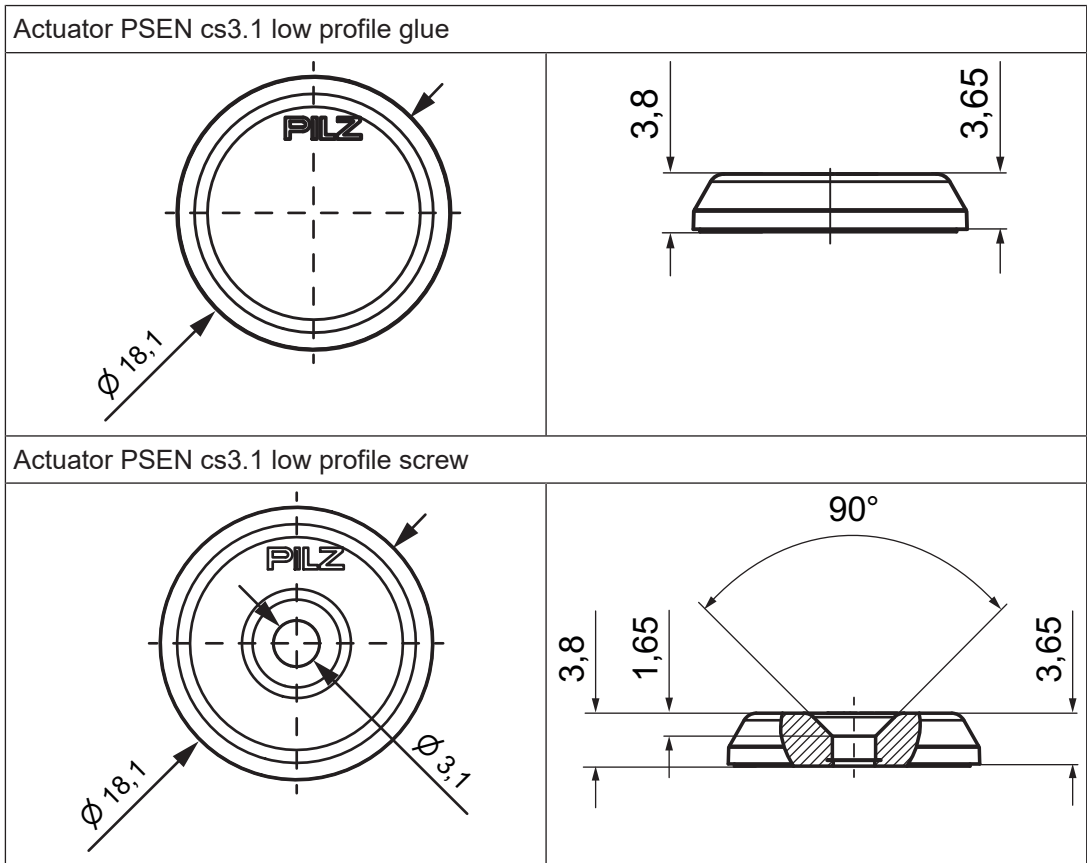

Fig.: Actuator PSEN cs3.1



Technical details safety switch

General	541061	541062
Certifications	CE, EAC (Eurasian), FCC, IC, TÜV, cULus Listed	CE, EAC (Eurasian), FCC, IC, TÜV, cULus Listed
Sensor's mode of operation	Transponder	Transponder
Coding level in accordance with EN ISO 14119	Low	Low
Design in accordance with EN ISO 14119	4	4
Classification in accordance with EN 60947-5-3	PDDB	PDDB
Pilz coding type	Coded	Coded
Transponder	541061	541062
Frequency band	122 kHz - 128 kHz	122 kHz - 128 kHz
Max. transmitter output	15 mW	15 mW
Electrical data	541061	541062
Supply voltage		
Voltage	24 V	24 V
Kind	DC	DC
Voltage tolerance	-20 %/+20 %	-20 %/+20 %
Output of external power supply (DC)	1 W	1 W
Max. switching frequency	3 Hz	3 Hz
Max. cable capacitance at the safety outputs		
No-load, PNOZ with relay contacts	400 nF	400 nF
PNOZmulti, PNOZelog, PSS	400 nF	400 nF
Max. inrush current impulse		
Current pulse, A1	0,58 A	0,58 A
Pulse duration, A1	1 ms	1 ms
No-load current	20 mA	20 mA
Inputs	541061	541062
Number	2	2
Voltage at inputs	24 V DC	24 V DC
Input current range	5 mA	5 mA
Max. overall cable resistance R _{I-max}		
Single-channel at UB DC	1000 Ohm	1000 Ohm
Semiconductor outputs	541061	541062
OSSD safety outputs	2	2
Signal outputs	1	1
Switching current per output	100 mA	100 mA
Breaking capacity per output	2,4 W	2,4 W
Potential isolation from system voltage	No	No

Semiconductor outputs	541061	541062
Short circuit-proof	yes	yes
Residual current at outputs	20 µA	20 µA
Voltage drop at OSSDs	3,5 V	3,5 V
Lowest operating current	0 mA	0 mA
Utilisation category in accordance with EN 60947-1	DC-12	DC-12
Times	541061	541062
Test pulse duration, safety outputs	450 µs	450 µs
Switch-on delay		
after UB is applied	1 s	1 s
Inputs typ.	13 ms	13 ms
Inputs max.	20 ms	20 ms
Actuator typ.	60 ms	60 ms
Actuator max.	150 ms	150 ms
Delay-on de-energisation		
Inputs typ.	15 ms	15 ms
Inputs max.	20 ms	20 ms
Actuator typ.	40 ms	40 ms
Actuator max.	260 ms	260 ms
Risk time in accordance with EN 60947-5-3	260 ms	260 ms
Supply interruption before de-energisation	10 ms	10 ms
Simultaneity, channel 1 and 2 max.	∞	∞
Environmental data	541061	541062
Ambient temperature		
In accordance with the standard	EN 60068-2-14	EN 60068-2-14
Temperature range	-25 - 70 °C	-25 - 70 °C
Storage temperature		
In accordance with the standard	EN 60068-2-1/-2	EN 60068-2-1/-2
Temperature range	-25 - 70 °C	-25 - 70 °C
Climatic suitability		
In accordance with the standard	EN 60068-2-78	EN 60068-2-78
Humidity	93 % r. h. at 40 °C	93 % r. h. at 40 °C
EMC	EN 60947-5-3	EN 60947-5-3
Vibration		
In accordance with the standard	EN 60947-5-2	EN 60947-5-2
Frequency	10 - 55 Hz	10 - 55 Hz
Amplitude	1 mm	1 mm
Shock stress		
In accordance with the standard	EN 60947-5-2	EN 60947-5-2
Acceleration	30g	30g
Duration	18 ms	18 ms

Environmental data	541061	541062
Airgap creepage		
Overvoltage category	III	III
Pollution degree	3	3
Rated insulation voltage	75 V	75 V
Rated impulse withstand voltage	0,8 kV	0,8 kV
Protection type		
Housing	IP6K9K	IP6K9K
Operating distances	541061	541062
Actuator 1		
Type	PSEN cs3.1	PSEN cs3.1
Assured operating distance Sao	8 mm	8 mm
Typical operating distance So	11 mm	11 mm
Assured release distance Sar	20 mm	20 mm
Typical release distance Sr	14 mm	14 mm
Repetition accuracy switching distances	10 %	10 %
Change of operating distance with temperature changes	+0,01mm/°C	+0,01mm/°C
Typ. Hysteresis	2 mm	2 mm
Actuator 2		
Type	PSEN cs1.1	PSEN cs1.1
Assured operating distance Sao	10 mm	10 mm
Typical operating distance So	25 mm	25 mm
Assured release distance Sar	33 mm	33 mm
Typical release distance Sr	29 mm	29 mm
Repetition accuracy switching distances	10 %	10 %
Change of operating distance with temperature changes	+0,1mm/°C	+0,1mm/°C
Typ. Hysteresis	3 mm	3 mm
Actuator 3		
Type	PSEN cs3.1 low profile glue	PSEN cs3.1 low profile glue
Assured operating distance Sao	5 mm	5 mm
Typical operating distance So	10 mm	10 mm
Assured release distance Sar	20 mm	20 mm
Typical release distance Sr	12 mm	12 mm
Repetition accuracy switching distances	10 %	10 %
Change of operating distance with temperature changes	+0,01mm/°C	+0,01mm/°C
Typ. Hysteresis	2 mm	2 mm

Operating distances	541061	541062
Actuator 4		
Typ	PSEN cs3.1 low profile screw	PSEN cs3.1 low profile screw
Assured operating distance S_{ao}	5 mm	5 mm
Typical operating distance S_o	10 mm	10 mm
Assured release distance S_{ar}	20 mm	20 mm
Typical release distance S_r	12 mm	12 mm
Repetition accuracy switching distances	10 %	10 %
Change of operating distance with temperature changes	+0,01mm/°C	+0,01mm/°C
Typical hysteresis	2 mm	2 mm
Mechanical data	541061	541062
Min. bending radius (fixed permanently) K1	5 x Ø	5 x Ø
Min. bending radius (moving) K1	10 x Ø	10 x Ø
Cable diameter K1	5,55 mm	5,55 mm
Min. distance between safety switches	100 mm	100 mm
Sensor flush installation in accordance with EN 60947-5-2	Yes, follow installation guidelines	Yes, follow installation guidelines
Connection type	5 m cable	10 m cable
Cable	Li9Y11Y 8 x 0,14 mm²	Li9Y11Y 8 x 0,14 mm²
Material		
Top	PBT	PBT
Max. torque setting for fixing screws	0,8 Nm	0,8 Nm
Dimensions		
Height	37 mm	37 mm
Width	26 mm	26 mm
Depth	18 mm	18 mm
Weight of safety switch	205 g	380 g

Where standards are undated, the 2016-10 latest editions shall apply.

Technical details actuator

Order no. 540080 - 541080

See below for more order numbers

General	540080	541080
Certifications	CE, EAC (Eurasian), TÜV, cULus Listed	CE, EAC (Eurasian), TÜV, cULus Listed
Sensor's mode of operation	Transponder	Transponder
Coding level in accordance with EN ISO 14119	Low	Low
Pilz coding type	Coded	Coded

Transponder	540080	541080
Frequency band	122 kHz - 128 kHz	122 kHz - 128 kHz
Environmental data	540080	541080
Ambient temperature		
In accordance with the standard	EN 60068-2-14	EN 60068-2-14
Temperature range	-25 - 70 °C	-25 - 70 °C
Storage temperature		
In accordance with the standard	EN 60068-2-1/-2	EN 60068-2-1/-2
Temperature range	-40 - 85 °C	-25 - 70 °C
Climatic suitability		
In accordance with the standard	EN 60068-2-78	EN 60068-2-78
Humidity	93 % r. h. at 40 °C	93 % r. h. at 40 °C
EMC	EN 60947-5-3	EN 60947-5-3
Vibration		
In accordance with the standard	EN 60947-5-2	EN 60947-5-2
Frequency	10 - 55 Hz	10 - 55 Hz
Amplitude	1 mm	1 mm
Shock stress		
In accordance with the standard	EN 60947-5-2	EN 60947-5-2
Acceleration	30g	30g
Duration	11 ms	18 ms
Protection type		
Housing	IP6K9K	IP6K9K
Mechanical data	540080	541080
Material	–	PBT
Material		
Top	PBT	–
Max. torque setting for fixing screws	1 Nm	0,8 Nm
Dimensions		
Height	11 mm	37 mm
Width	40 mm	18 mm
Depth	40 mm	18 mm
Weight	20 g	10 g

Order no. 541087 - 541088

General	541087	541088
Certifications	CE, EAC (Eurasian), TÜV, cULus Listed	CE, EAC (Eurasian), TÜV, cULus Listed
Sensor's mode of operation	Transponder	Transponder
Coding level in accordance with EN ISO 14119	Low	Low
Pilz coding type	Coded	Coded
Transponder	541087	541088
Frequency band	122 kHz - 128 kHz	122 kHz - 128 kHz

Environmental data	541087	541088
Ambient temperature		
In accordance with the standard	EN 60068-2-14	EN 60068-2-14
Temperature range	-25 - 70 °C	-25 - 70 °C
Max. at max. operating height	+60 °C	+60 °C
Max. at max. operating height <2000 m	+70 °C	+70 °C
Storage temperature		
In accordance with the standard	EN 60068-2-1/-2	EN 60068-2-1/-2
Temperature range	-40 - 85 °C	-40 - 85 °C
Climatic suitability		
In accordance with the standard	EN 60068-2-30	EN 60068-2-30
Humidity	93 % r. h. at 40 °C	93 % r. h. at 40 °C
Max. operating height above sea level		
	4000 m	4000 m
EMC		
	EN 60947-5-3	EN 60947-5-3
Vibration		
In accordance with the standard	EN 60947-5-2	EN 60947-5-2
Frequency	10 - 55 Hz	10 - 55 Hz
Amplitude	1 mm	1 mm
Shock stress		
In accordance with the standard	EN 60947-5-2	EN 60947-5-2
Acceleration	30g	30g
Duration	11 ms	11 ms
Protection type		
Housing	IP67	IP67
Mechanical data	541087	541088
Material		
Top	PBT	PBT
Max. torque setting for fixing screws		
	–	0,1 Nm
Dimensions		
Height	3,8 mm	3,8 mm
Width	18 mm	18 mm
Depth	18 mm	18 mm
Weight		
	2 g	2 g

Where standards are undated, the 2016-10 latest editions shall apply.

Classification according to ZVEI, CB24I

The following tables describe the classes and specific values of the product interface and the classes of interfaces compatible with it. The classification is described in the ZVEI position paper "Classification of Binary 24 V Interfaces - Functional Safety aspects covered by dynamic testing".

Input	
Interfaces	
Drain	
Class	C2
Source	
Class	C2, C3
Drain parameters	
Test pulse duration, safety outputs	500 μ s
Min. test pulse interval	1,25 ms
Min. input resistance	6,6 Ohm
Max. capacitive load	18 pF
Single-pole output	
Interfaces	
Source	
Interface	Sensor
Class	C2
Drain	
Class	C1, C2
Source parameters	
Max. test pulse duration	450 μ s
Max. rated current	0,1 A
Max. capacitive load	0,4 μ F

Safety characteristic data



NOTICE

You must comply with the safety characteristic data in order to achieve the required safety level for your plant/machine.

Operating mode	EN ISO 13849-1: 2015 PL	EN ISO 13849-1: 2015 Category	EN 62061 SIL CL	EN 62061 PFH _D [1/h]	IEC 61511 SIL	IEC 61511 PFD	EN ISO 13849-1: 2015 T _M [year]
2-ch. OSSD	PL e	Cat. 4	SIL CL 3	2,62E-09	–	7,68E-05	20

Explanatory notes for the safety-related characteristic data:

- ▶ The SIL CL value in accordance with EN 62061 corresponds to the SIL value in accordance with EN 61508.
- ▶ T_M is the maximum mission time in accordance with EN ISO 13849-1. The value also applies as the retest interval in accordance with EN 61508-6 and IEC 61511 and as the proof test interval and mission time in accordance with EN 62061.

All the units used within a safety function must be considered when calculating the safety characteristic data.



INFORMATION

A safety function's SIL/PL values are **not** identical to the SIL/PL values of the units that are used and may be different. We recommend that you use the PASCAL software tool to calculate the safety function's SIL/PL values.

Supplementary data

Radio approval

USA/Canada

FCC ID: VT8-PSENCSS3
IC: 7482A-PSENCSS3

FCC/IC-Requirements:

This product complies with Part 15 of the FCC Rules and with Industry Canada licence-exempt RSS standards.

Operation is subject to the following two conditions:

- 1) this product may not cause harmful interference, and
- 2) this product must accept any interference received, including interference that may cause undesired operation.

Changes or modifications made to this product not expressly approved by Pilz may void the FCC authorization to operate this equipment.

NOTE: This equipment has been tested and found to comply with the limits for a Class A digital device, pursuant to Part 15 of the FCC Rules. These limits are designed to provide reasonable protection against harmful interference when the equipment is operated in a commercial environment. This equipment generates, uses, and can radiate radio frequency energy and, if not installed and used in accordance with the instruction manual, may cause harmful interference to radio communications. Operation of this equipment in a residential area is likely to cause harmful interference in which case the user will be required to correct the interference at his own expense.

Le présent produit est conforme aux CNR d'Industrie Canada applicables aux appareils radio exempts de licence. L'exploitation est autorisée aux deux conditions suivantes:

- (1) le produit ne doit pas produire de brouillage, et
- (2) l'utilisateur de le produit doit accepter tout brouillage radioélectrique subi, même si le brouillage est susceptible d'en compromettre le fonctionnement.

Order reference

Safety switch

Product type	Features		Order no.
PSEN cs3.1a 1switch	Safety switch, coded	Cable, 5 m	541 061
PSEN cs3.1b 1switch	Safety switch, coded	Cable, 10 m	541 062

Actuator

Product type	Features		Order no.
PSEN cs1.1 1 actu- ator	Actuator, coded		540 080
PSEN cs3.1 1 actu- ator	Actuator, coded		541 080
PSEN cs3.1 low pro- file glue 1 actuator	Actuator coded, without screw		541 087
PSEN cs3.1 low pro- file screw 1 actuator	Actuator coded, with screw		541 088

Complete systems

Product type	Features		Order no.
PSEN cs3.1a /PSEN cs3.1 1unit	Safety gate system, coded	Cable, 5 m	541 011
PSEN cs3.1b /PSEN cs3.1 1unit	Safety gate system, coded	Cable, 10 m	541 012

Accessories**Installation materials**

Product type	Features	Order no.
PSEN bracket	Mounting bracket	532 110
PSEN mag/cs bracket straight	Mounting aid	532 111
PSEN screw M4x20 10pcs	Safety screws made from stainless steel with one-way slot	540 313
PSEN screw M4x26 10pcs	Safety screws made from stainless steel with one-way slot	540 314

Cable

Product type	Connection 1	Connection 2	Length	Order no.
PSEN cable M12-8sf	Straight, M12, 8-pin, socket	Open cable	3 m	540 319
			5 m	540 320
			10 m	540 321
			20 m	540 333
			30 m	540 326
PSEN cable M12-8af	Angled, M12, 8-pin, socket	Open cable	3 m	540 322
			5 m	540 323
			10 m	540 324
			30 m	540 325
PSEN cable M12-8sf M12-8sm	straight, M12, 8-pin, socket	straight, M12, 8-pin, pin	2 m	540 340
			5 m	540 341
			10 m	540 342
			20 m	540 343
			30 m	540 344

Series connection

Product type	Connection X1	Connection X2	Connection X3	Order no.
PSEN Y junction M12 SENSOR	M12, 8-pin, pin	M12, 8-pin, socket	M12, 8-pin, socket	540 315
PSEN Y junction M12 cable channel	M12, 8-pin, pin	M12, 8-pin, socket	M12, 8-pin, socket	540 316
PSEN T junction M12	M12, 8-pin, socket	M12, 8-pin, pin	M8, 4-pin, pin	540 331
PSEN Y junction M8-M12/ M12 PIGTAIL	M12, 8-pin, socket	M12, 8-pin, pin	M8, 8-pin, socket	540 337
PSEN Y junction M12-M12/ M12 PIGTAIL	M12, 8-pin, socket	M12, 8-pin, pin	M12, 8-pin, socket	540 338
PDP67 F 4 code	Decentralised passive junction			773 603
PDP67 F 4 code VA	Decentralised passive junction, V2A ring nut			773 613

Safety Device Diagnostics

Product type	Features	Connection type	Order no.
PSEN ix2 F4 code	Interface for connecting max. 4 PSEN safety sensors	Spring-loaded terminal	535 111
PSEN ix2 F8 code	Interface for connecting max. 8 PSEN safety sensors	Spring-loaded terminal	535 112
SDD ES ETH	Fieldbus module Modbus/ TCP for Safety Device Diagnostics	Spring-loaded terminal	540 130
SDD ES Profibus	Fieldbus module Profibus for Safety Device Diagnostics	Spring-loaded terminal	540 132
SDD ES Profinet	Fieldbus module for Safety Device Diagnostics	Spring-loaded terminal	540 138

EC declaration of conformity

This product/these products meet the requirements of the following directives of the European Parliament and of the Council.

- ▶ 2006/42/EC on machines
- ▶ 2014/53/EC on radio equipment

The complete EC Declaration of Conformity is available on the Internet at www.pilz.com/downloads.

Representative: Norbert Fröhlich, Pilz GmbH & Co. KG, Felix-Wankel-Str. 2, 73760 Ostfildern, Germany

► Support

Technical support is available from Pilz round the clock.

Americas

Brazil
+55 11 97569-2804

Canada
+1 888 315 7459

Mexico
+52 55 5572 1300

USA (toll-free)
+1 877-PILZUSA (745-9872)

Asia

China
+86 21 60880878-216

Japan
+81 45 471-2281

South Korea
+82 31 778 3300

Australia

+61 3 95600621

Europe

Austria
+43 1 7986263-0

Belgium, Luxembourg
+32 9 3217570

France
+33 3 88104003

Germany
+49 711 3409-444

Ireland
+353 21 4804983

Italy, Malta
+39 0362 1826711

Scandinavia

+45 74436332

Spain

+34 938497433

Switzerland

+41 62 88979-32

The Netherlands

+31 347 320477

Turkey

+90 216 5775552

United Kingdom

+44 1536 462203

You can reach our international hotline on:

+49 711 3409-444
support@pilz.com

Pilz develops environmentally-friendly products using ecological materials and energy-saving technologies. Offices and production facilities are ecologically designed, environmentally-aware and energy-saving. So Pilz offers sustainability, plus the security of using energy-efficient products and environmentally-friendly solutions.



We are represented internationally. Please refer to our homepage www.pilz.com for further details or contact our headquarters.

Headquarters: Pilz GmbH & Co. KG, Felix-Wankel-Straße 2, 73760 Ostfildern, Germany
Telephone: +49 711 3409-0, Telefax: +49 711 3409-133, E-Mail: info@pilz.com, Internet: www.pilz.com

PILZ
THE SPIRIT OF SAFETY

1003295-EN-08, 2020-03 Printed in Germany
© Pilz GmbH & Co. KG, 2019

CECC®_CHRE®, CMSE®, InduraNET p®, Leansafe®, Master of Safety®, Master of Security®, PAS4000®, PAScall®, PASconfig®, Pilz®, PTT®, PLID®, PMCPirimo®, PMCPiritego®, PMCTendo®, PMD®, PMJ®, PNOZ®, PRBT®, PRCM®, PRCM®, PRM®, PRM®, PRM®, PSEN®, PSS®, PVS®, SafetyBUS p®, SafetyEYE®, SafetyNET p®, THE SPIRIT OF SAFETY® are registered and protected trademarks of Pilz GmbH & Co. KG in some countries. We would point out that product features may vary from the details stated in this document, depending on the status at the time of publication and the scope of the equipment. We accept no responsibility for the validity, accuracy and entirety of the text and graphics presented in this information. Please contact our Technical Support if you have any questions.