

# PowerFlex 750-Series ATEX Option Module

Catalog Number 20-750-ATEX



## Important User Information

Read this document and the documents listed in the additional resources section about installation, configuration, and operation of this equipment before you install, configure, operate, or maintain this product. Users are required to familiarize themselves with installation and wiring instructions in addition to requirements of all applicable codes, laws, and standards.

Activities including installation, adjustments, putting into service, use, assembly, disassembly, and maintenance are required to be carried out by suitably trained personnel in accordance with applicable code of practice.

If this equipment is used in a manner not specified by the manufacturer, the protection provided by the equipment may be impaired.

In no event will Rockwell Automation, Inc. be responsible or liable for indirect or consequential damages resulting from the use or application of this equipment.

The examples and diagrams in this manual are included solely for illustrative purposes. Because of the many variables and requirements associated with any particular installation, Rockwell Automation, Inc. cannot assume responsibility or liability for actual use based on the examples and diagrams.

No patent liability is assumed by Rockwell Automation, Inc. with respect to use of information, circuits, equipment, or software described in this manual.

Reproduction of the contents of this manual, in whole or in part, without written permission of Rockwell Automation, Inc., is prohibited.

Throughout this manual, when necessary, we use notes to make you aware of safety considerations.



**WARNING:** Identifies information about practices or circumstances that can cause an explosion in a hazardous environment, which may lead to personal injury or death, property damage, or economic loss.



**ATTENTION:** Identifies information about practices or circumstances that can lead to personal injury or death, property damage, or economic loss. Attentions help you identify a hazard, avoid a hazard, and recognize the consequence.

---

**IMPORTANT** Identifies information that is critical for successful application and understanding of the product.

---

Labels may also be on or inside the equipment to provide specific precautions.



**SHOCK HAZARD:** Labels may be on or inside the equipment, for example, a drive or motor, to alert people that dangerous voltage may be present.



**BURN HAZARD:** Labels may be on or inside the equipment, for example, a drive or motor, to alert people that surfaces may reach dangerous temperatures.



**ARC FLASH HAZARD:** Labels may be on or inside the equipment, for example, a motor control center, to alert people to potential Arc Flash. Arc Flash will cause severe injury or death. Wear proper Personal Protective Equipment (PPE). Follow ALL Regulatory requirements for safe work practices and for Personal Protective Equipment (PPE).

---

**Preface**

Summary of Changes ..... 5  
 About the PowerFlex 750-Series ATEX Option Module ..... 7  
 Catalog Numbers for ATEX and 11-Series I/O Option Modules... 7  
 Catalog Numbers for Spare Terminal Plugs..... 7  
 Additional Resources ..... 8

**Chapter 1**

**Safety Concepts**

ATEX Directive 2014/34/EU ..... 9  
 Motor Requirements ..... 10  
 ATEX System ..... 11  
 ATEX Function ..... 11  
     Thermostat Trip ..... 12  
     Positive Temperature Coefficient (PTC) Trip ..... 12  
 Safe State ..... 12  
 Hardware Fault Tolerance ..... 13  
 Safety Reaction Time ..... 13  
 Contact Information If Safety Option Failure Occurs ..... 13

**Chapter 2**

**Installation and Wiring**

Perform a Risk Assessment of the Operational Environment ..... 15  
 Perform a Safety Analysis of the Motor ..... 16  
 Access the Drive Control Pod ..... 16  
     Remove the Drive Cover for Frame 1 ..... 16  
     Remove the Drive Cover for Frames 2...5 ..... 17  
     Remove the Drive Cover for Frames 6 and 7 ..... 18  
     Remove the Drive Cover for Frames 8...12 ..... 19  
 Configure the Hardware ..... 21  
     S1 Switch Location ..... 21  
     Safety Enable Jumper Locations ..... 22  
     ATEX Option Module and 11-Series I/O Option Module  
     without a Safety Option Module ..... 23  
     ATEX Option Module and 11-Series I/O Option Module  
     with a Safety Option Module ..... 24  
     Assemble the ATEX and 11-Series I/O Option Modules ..... 25  
 Connect the Thermal Sensor Wires ..... 26  
     Cabling Requirements ..... 26  
     Installation Requirements ..... 27  
 Install the ATEX Option Module Assembly ..... 27  
 Safe Torque Off Option Wiring ..... 30  
 Safe Speed Monitor Option Wiring ..... 31  
 Reset the Drive after an SSM Fault Detection ..... 32  
 Interface Without a Safety Option ..... 32

	<b>Chapter 3</b>	
<b>Verify Operation</b>	Description of Functionality .....	33
	Motors with Thermostatic Switches .....	34
	Functional Proof Testing for Systems with Thermostat Contacts .....	34
	Motors with Positive Temperature Coefficient (PTC) Devices. ....	35
	Functional Proof Testing for Systems with PTC Devices. ....	35
	Functional Proof Testing without a Test Fixture.....	36
	<b>Chapter 4</b>	
<b>ATEX Monitoring</b>	Parameter 41 [ATEX Sts].....	39
	ATEX Fault Descriptions.....	40
	ATEX Configuration Errors .....	40
	Restart the Drive after an Over-temperature Fault .....	41
	<b>Appendix A</b>	
<b>Specifications and Certifications</b>	General Specifications .....	43
	11-Series I/O Option Module Terminal Block Specifications .....	43
	Safety Data .....	44
	Environmental Specifications .....	44
	Certifications .....	45
	<b>Index</b> .....	47

## Summary of Changes

This manual contains new and updated information as indicated in the following table.

Topic	Page
Added a mini table of contents to the beginning of each section.	–
Replaced European Union Directive 94/9/EU with the new directive number throughout the user manual 2014/34/EU	–
Added reference to these new products: <ul style="list-style-type: none"> <li>• PowerFlex 755TL low harmonic drives</li> <li>• PowerFlex 755TR regenerative drives</li> <li>• PowerFlex 755TM drive systems</li> </ul> (Throughout this manual, the PowerFlex 755TL low harmonic drives, PowerFlex 755TR regenerative drives, and PowerFlex 755TM drive systems are also referred to as PowerFlex 755T drive products.)	7
Added manuals for the new modular drives to the Additional Resources table.	8
Relocated ATEX Directive and Motor Requirements content from the Preface to Chapter 1.	9, 10
Added new ATEX System content to Chapter 1.	11
Updated the EN and IEC standards for hardware fault tolerance.	13
Added the PowerFlex 755T drive products to the safety reaction time table.	13
Added the PowerFlex 755T drive products to instructions to remove the drive cover.	19
Added a drawing of the location of the safety enable jumper on the main control board of the PowerFlex 755T drive products.	22
Added a drawing of the safety enable jumper installed on the main control board of the PowerFlex 755T drive products.	23
Added a drawing of the safety enable jumper removed from the main control board of the PowerFlex 755T drive products.	24
Added a statement to clarify to remove only the jumper that slides off of the pins, and do not attempt to remove the pins from the option module.	24
Added DC voltage test points for PowerFlex 755T drive products.	27, 36
Added statement for PowerFlex 755T drive products to check the firmware release notes for known anomalies and verify that there are no safety-related anomalies.	33
Replaced the environmental specifications table with links to the technical data publications for the different drives.	44
Changed the heading for Risk Assessment Data to Safety Data and moved the content to Appendix A.	44
Added information for environmental pollution degree.	44
Updated the index.	47

The PowerFlex® ATEX option module and the 11-Series I/O option module for PowerFlex 750-Series AC drives and PowerFlex 755T drive products are safety system components of the equipment and protective systems. The option modules are intended for equipment that is used in potentially explosive atmospheres (ATEX). Perform a risk assessment and safety analysis of the operating atmosphere and the ATEX system components before you begin this ATEX installation:

- PowerFlex 750-Series drive
- PowerFlex 755TL low harmonic drives <sup>(1)</sup>
- PowerFlex 755TR regenerative drives <sup>(1)</sup>
- PowerFlex 755TM drive systems <sup>(1)</sup>
- Motor
- ATEX option module
- 11-Series I/O option module

Throughout this manual, PowerFlex 755T drive products is used to refer to PowerFlex 755TL drives, PowerFlex 755TR drives, and PowerFlex 755TM drive systems.

See [Installation and Wiring on page 15](#).

---

**IMPORTANT** Read and understand this user manual before you begin to design and install your ATEX system.

---

(1) Throughout this manual, the PowerFlex 755TL low harmonic drives, PowerFlex 755TR regenerative drives, and PowerFlex 755TM drive systems are also referred to as PowerFlex 755T drive products.

## About the PowerFlex 750-Series ATEX Option Module

The ATEX option module with the 11-Series I/O option module enables a PowerFlex 750-Series drive and PowerFlex 755T drive products to be used in ATEX installations. The ATEX option module helps to reduce the risk of explosion due to an over-temperature condition in an ATEX approved motor. In an ATEX installation, the motor is installed in a potentially explosive atmosphere, while the drive is installed outside of the potentially explosive atmosphere. See [Figure 1 on page 11](#).



**WARNING:** Risk of Explosion.

Do not install the PowerFlex 750-Series drive or PowerFlex 755T drive products in a potentially explosive atmosphere.

A drive that is installed in a potentially explosive atmosphere can cause an explosion.

## Catalog Numbers for ATEX and 11-Series I/O Option Modules

This table lists the catalog numbers for the ATEX option module and the compatible 11-Series I/O option modules.

ATEX Option Module Cat. No.	11-Series I/O Option Module Cat. No.	Description
20-750-ATEX	20-750-1132D-2R	115V AC digital input Two relay outputs, digital
	20-750-1133C-1R2T	24V DC digital input Two transistor outputs, one relay output, digital
	20-750-1132C-2R	24V DC digital input Two relay outputs, digital

## Catalog Numbers for Spare Terminal Plugs

This table contains the catalog numbers for the 11-Series I/O option module spare terminal plug kits.

Cat. No.	Spare Terminal Plug Kit
SK-R1-SCRWTB-EIO	Screw-down terminal plugs spare kit (set of three)
SK-R1-SPRGTB-EIO	Spring-clamp terminal plugs spare kit (set of three)

## Additional Resources

These documents contain additional information concerning related products from Rockwell Automation.

Resource	Description
PowerFlex 750-Series Products with TotalFORCE™ Control Installation Instructions, publication <a href="#">750-IN100</a>	Provides the basic steps to install PowerFlex 755TL low harmonic drives, PowerFlex 755TR regenerative drives, and PowerFlex 755TM drive systems.
PowerFlex 755TM IP00 Open Type Kits Installation Instructions, publication <a href="#">750-IN101</a>	Provides instructions to install IP00 Open Type kits in user-supplied enclosures.
PowerFlex 750-Series AC Drives Installation Instructions, publication <a href="#">750-IN001</a>	Provides the basic steps to install PowerFlex 750-Series AC drives.
PowerFlex Drives with TotalFORCE Control Programming Manual, publication <a href="#">750-PM100</a> PowerFlex 750-Series AC Drives Programming Manual, publication <a href="#">750-PM001</a>	Provides detailed information on: <ul style="list-style-type: none"> <li>• I/O, control, and feedback options</li> <li>• Parameters and programming</li> <li>• Faults, alarms, and troubleshooting</li> </ul>
PowerFlex 750-Series AC Drives Technical Data, publication <a href="#">750-TD001</a>	Provides detailed information on: <ul style="list-style-type: none"> <li>• Drive and bus supply specifications</li> <li>• Option specifications</li> <li>• Fuse and circuit breaker ratings</li> </ul>
PowerFlex 750-Series Products with TotalFORCE Control Technical Data, publication <a href="#">750-TD100</a>	
PowerFlex 755TM IP00 Open Type Kits Technical Data, publication <a href="#">750-TD101</a>	Provides detailed information on: <ul style="list-style-type: none"> <li>• Kit selection</li> <li>• Kit ratings and specifications</li> <li>• Option specifications</li> </ul>
PowerFlex 750-Series Safe Torque Off User Manual, publication <a href="#">750-UM002</a>	Provides information for the Safe Torque Off option that can be used as a component in a safety control system.
Safe Speed Monitor Option Module for PowerFlex 750-Series AC Drives Safety Reference Manual, publication <a href="#">750-RM001</a>	Provides information for the Safe Speed Monitor option that can be used as a component in a safety control system.
Industrial Automation Wiring and Grounding Guidelines, publication <a href="#">1770-4.1</a>	Provides general guidelines for installing a Rockwell Automation industrial system.
Product Certifications website, <a href="http://www.rockwellautomation.com/global/certification/overview.page">http://www.rockwellautomation.com/global/certification/overview.page</a>	Provides declarations of conformity, certificates, and other certification details.

You can view or download publications at <http://www.rockwellautomation.com/global/literature-library/overview.page>. To order paper copies of technical documentation, contact your local Allen-Bradley distributor or Rockwell Automation sales representative.



## Safety Concepts

Topic	Page
ATEX Directive 2014/34/EU	9
Motor Requirements	10
ATEX System	11
ATEX Function	11
Safe State	12
Hardware Fault Tolerance	13
Safety Reaction Time	13
Contact Information If Safety Option Failure Occurs	13

The PowerFlex® ATEX option module that is installed in a PowerFlex 750-Series drive or PowerFlex 755T drive products and equipped with an 11-Series I/O option module provides an ATEX-compliant safety function. This ATEX-compliant function provides a safe turn-off for equipment that is installed in a potentially explosive atmosphere according to 2014/34/EU.

### ATEX Directive 2014/34/EU

The PowerFlex 750-Series drives and PowerFlex 755T drive products, together with the ATEX and 11-Series I/O option modules, are compliant safety devices under the ATEX directive 2014/34/EU, and satisfy requirements for use in Group II, Category 2, (GD) applications with ATEX approved motors as described here:

- Group II – The motor is installed in a potentially explosive atmosphere that is not in a mine.
- Category 2 – The motor is likely to be exposed to an explosive atmosphere. A high level of protection is required.
- GD – The explosive atmosphere consists of a mixture of (G) gas vapors and (D) dust that can cause an explosion.

Certification of the drive for the ATEX group and category on its nameplate is based on installation, operation, and maintenance according to these items:

- This user manual
- The requirements in the drive user manual and installation instructions
- The instruction manual for the motor



**ATTENTION:** Follow all procedures in the standard installation and user manuals for the ATEX-certified drive with an ATEX-certified motor. You must also follow all additional instructions in this PowerFlex 750-Series ATEX Option Module User Manual. Equipment damage and/or personal injury can result if all additional instructions in this user manual are not followed.

## Motor Requirements

- The motor must be manufactured under the guidelines of the ATEX directive 2014/34/EU. The motor must be installed, operated, and maintained according to the instructions of the motor manufacturer.
- Only motors with nameplates that are marked for use on an inverter power source, and labeled for specific hazardous areas, can be used in hazardous areas on inverter (variable frequency) power.
- When the motor is rated ATEX Group II, Category 2 for use in gas environments (category 2G), the motor must be of flameproof construction, EEx d (according to EN 50018) or Ex d (according to EN 60079-1 or IEC 60079-1). Group II motors are marked with a temperature or a temperature code.
- When the motor is rated ATEX Group II, Category 2 for use in dust environments (category 2D), the motor must be protected by an enclosure (according to EN 50281-1-1, or according to IEC 61241-1: Ex tD). Group II motors are marked with a temperature.
- The motor over-temperature signal is supplied to the drive by one of two methods:
  - A normally closed contact (open during over temperature condition) compatible with the digital (logic) input circuitry of the drive. If multiple sensors are required in the motor, the connection at the drive must be the result of all required contacts that are wired in series.
  - A positive temperature coefficient (PTC) type of thermal sensor. See [Appendix A](#) for specifications.
- See all product markings for additional cautions.
- Typical motor markings are contained on a motor certification nameplate similar to the sample here.

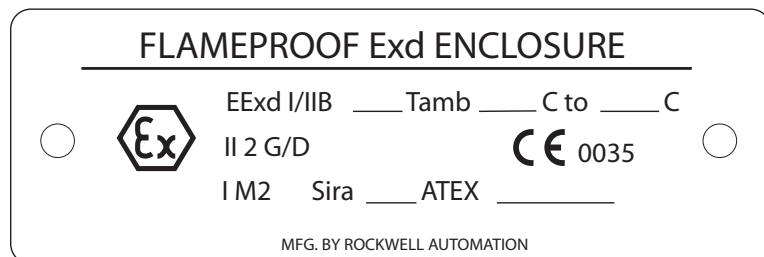

## ATEX System

The overall system includes an ATEX certified motor that is installed in a potentially explosive atmosphere. The motor is equipped with a thermal sensor that is connected to the ATEX option input. Do not install the drive in a potentially explosive atmosphere. See [Figure 1](#).



**WARNING:** Risk of Explosion.

Do not install the PowerFlex 750-Series drive or PowerFlex 755T drive products in a potentially explosive atmosphere.

A drive that is installed in a potentially explosive atmosphere can cause an explosion.

**Figure 1 - Basic ATEX Application**

PowerFlex 750-Series Drive or PowerFlex 755T drive products (750-Series drive shown)

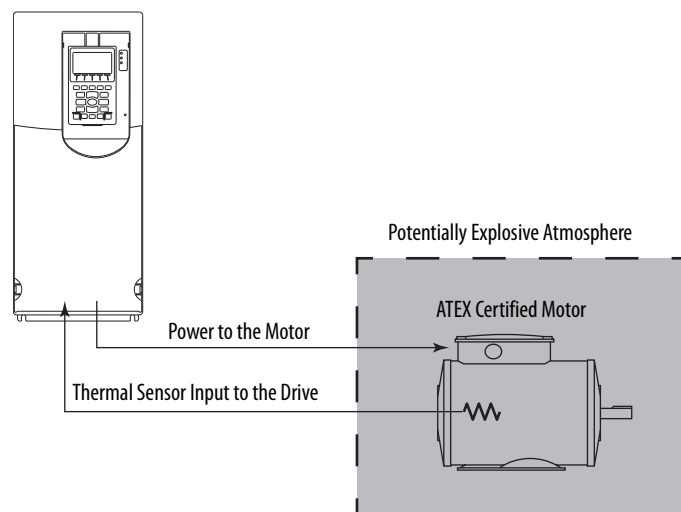

The ATEX option module monitors the thermal sensor in the motor. When the thermal sensor reaches its trip point, the drive initiates a Safe Torque Off function and removes torque-producing power from the motor. The ATEX safety function has a safety integration level (SIL) capability limit of 1 according to IEC 61508.

## ATEX Function

The PowerFlex 750-Series ATEX option module can be configured to support ATEX certified motors that are equipped with either a thermostat or a PTC-type thermal sensor.



**ATTENTION:** Risk of electric shock. If a motor insulation fault occurs, high voltage can be present at the ATEX terminal block and wiring. Be sure that all drive covers are installed when power is applied to the drive.

## Thermostat Trip

When the circuit is configured to trip with a thermostat, the ATEX option module supports a normally closed, dry-contact thermostat. The safe-off function initiates when the ATEX option module detects that the contact is open. This trip can be the result of a broken wire, or an over-temperature condition in the motor.

## Positive Temperature Coefficient (PTC) Trip

When the circuit is configured to trip with a PTC-type thermal sensor, the ATEX option module supports sensors with characteristics according to DIN 44081/DIN 440. The 'Mark A' measuring circuit on the ATEX option module is designed in accordance to IEC 60947-8 or EN 60947-8. This circuit trips when the motor temperature has reached its trip point, or an open-wire/short-circuit condition is detected in the sensor circuit.

Loss of voltage to the measuring circuit also initiates the safe-off function. The ATEX option module internally sources this voltage.

**Figure 2 - ATEX Circuitry**

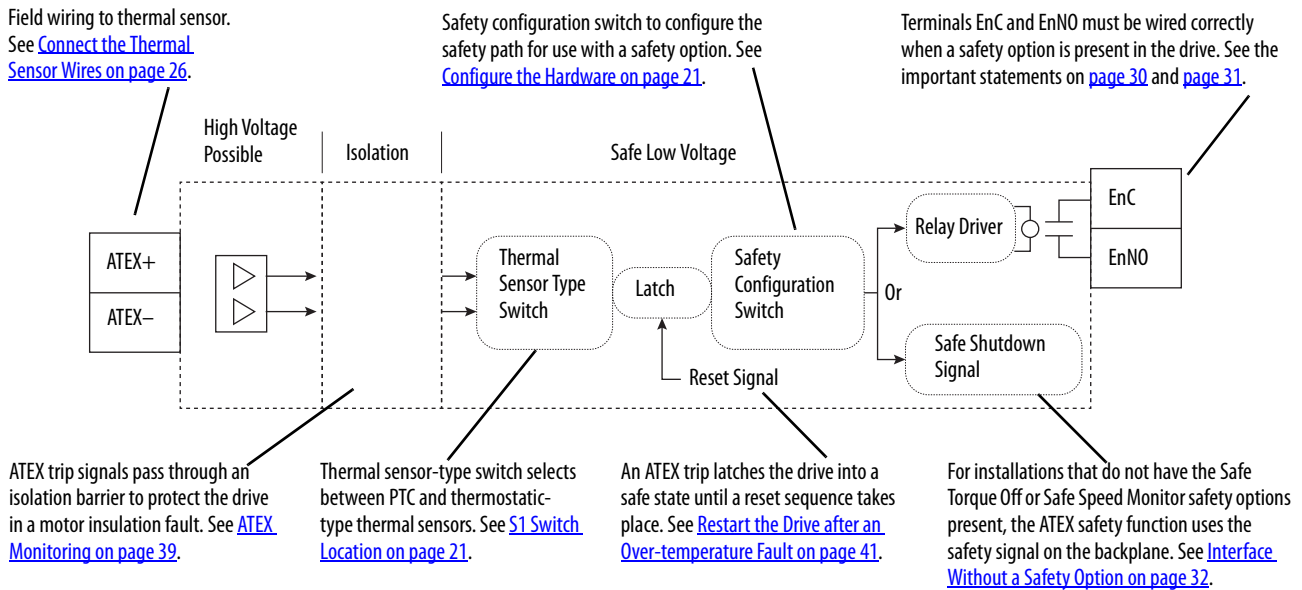

## Safe State

The safe state includes all operation that occurs outside of the other monitoring and stopping behavior that is defined as part of the ATEX option module. The ATEX safety function, as provided by the ATEX option module, places the drive in a safe state by removing the power from the gate firing circuits of the output power devices (IGBTs).

## Hardware Fault Tolerance

Hardware fault tolerance is the minimum number of faults that can cause a loss of the safety function as defined by EN 61800-5-2 and IEC 61508 part 2. The overall ATEX function has a hardware fault tolerance of zero.

---

**IMPORTANT** If one fault occurs in the safety path, the safety function can become compromised.

---

## Safety Reaction Time

The safety reaction time is the amount of time from a safety-related event as input to the system until the system is in the safe state.

The safety reaction time from an input signal trigger to the initiation of the ATEX safety function.

**Table 1 - Safety Reaction Time**

Drive	Safety Reaction Time
PowerFlex 753 drives	30 ms (max)
PowerFlex 755 drives	
PowerFlex 755TL low harmonic drives	
PowerFlex 755TR regenerative drives	
PowerFlex 755TM drive systems	

## Contact Information If Safety Option Failure Occurs

If you experience a failure with any safety-certified device, contact your local Allen-Bradley distributor to do the following:

- Return the device to Rockwell Automation so the failure is appropriately logged for the catalog number that is affected and a record is made of the failure.
- Request a failure analysis (if necessary) to determine the probable cause of the failure.

**Notes:**

## Installation and Wiring

Topic	Page
Perform a Risk Assessment of the Operational Environment	15
Perform a Safety Analysis of the Motor	16
Access the Drive Control Pod	16
Configure the Hardware	21
Connect the Thermal Sensor Wires	26
Install the ATEX Option Module Assembly	27
Safe Torque Off Option Wiring	30
Safe Speed Monitor Option Wiring	31
Reset the Drive after an SSM Fault Detection	32
Interface Without a Safety Option	32

You must follow the installation steps that are described in this installation and wiring section. The installation and wiring steps must be performed by qualified drive installation personnel. The PowerFlex® 750-Series ATEX option module with an 11-Series I/O module is part of an ATEX safety control system.



**ATTENTION:** Only qualified personnel familiar with adjustable frequency AC drives and associated machinery can plan or implement the installation, start-up, and subsequent maintenance of the system. Failure to comply can result in personal injury and/or equipment damage.



**ATTENTION:** The following information is a guide for proper installation. Rockwell Automation does not assume responsibility for the compliance or the noncompliance to any code, national, local, or otherwise, for the proper installation of this equipment. Personal injury and/or equipment damage can occur if codes are ignored during installation.

### Perform a Risk Assessment of the Operational Environment

Before you begin the installation, perform a risk assessment to compare the ATEX option specifications with the potentially explosive atmosphere where you want to install the system. See [Safety Concepts on page 9](#).

## Perform a Safety Analysis of the Motor

The ATEX safety system includes the thermal sensor in the motor and the wiring to the ATEX daughter card. [Verify Operation on page 33](#) gives methods for functional tests of the system from the input to the ATEX daughter card, but these tests do not verify the thermal sensor response or the wiring from the motor. Follow the recommendations of the motor manufacturer for safe use of the motor in ATEX installations and possible functional test procedures.

## Access the Drive Control Pod

Different frame sizes have different ways to access the control pod. To access the control pod, follow the steps for your drive and frame size.

- [Remove the Drive Cover for Frame 1 on page 16](#)
- [Remove the Drive Cover for Frames 2...5 on page 17](#)
- [Remove the Drive Cover for Frames 6 and 7 on page 18](#)
- [Remove the Drive Cover for Frames 8...12 on page 19](#)

### Remove the Drive Cover for Frame 1

To remove the drive cover for PowerFlex 753 and 755 frame 1 drives, follow these steps.

1. Squeeze the locking tabs and pull out the bottom of the cover.
2. Pull the cover down and away from the chassis.

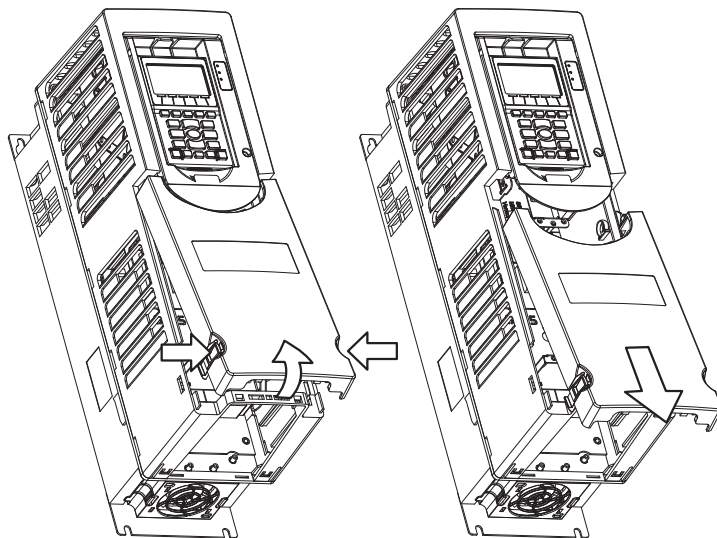

3. Lift the chassis cover.
  - a. Loosen the retention screw.
  - b. Use a screwdriver to release the chassis-cover locking tabs.
  - c. Lift the chassis until the latch engages.



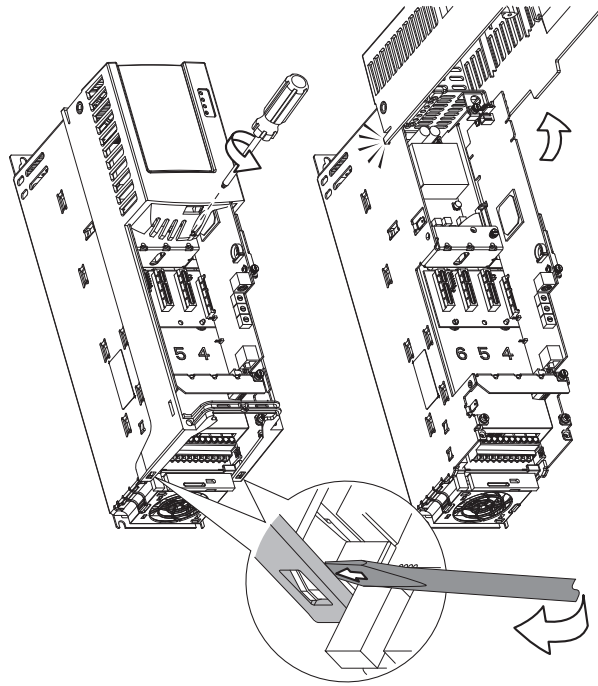

### Remove the Drive Cover for Frames 2...5

To remove the drive cover for PowerFlex 753 and 755 frame 2...5 drives, follow these steps.

1. Squeeze the locking tabs and pull out the bottom of the cover.
2. Pull the cover down and away from the chassis.

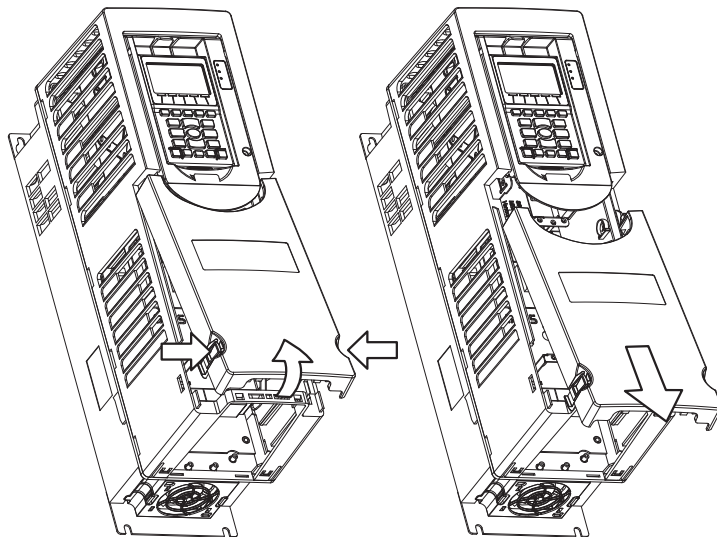

3. Lift the human interface module (HIM) cradle.
  - a. Loosen the retention screw.
  - b. Lift the cradle until the latch engages.

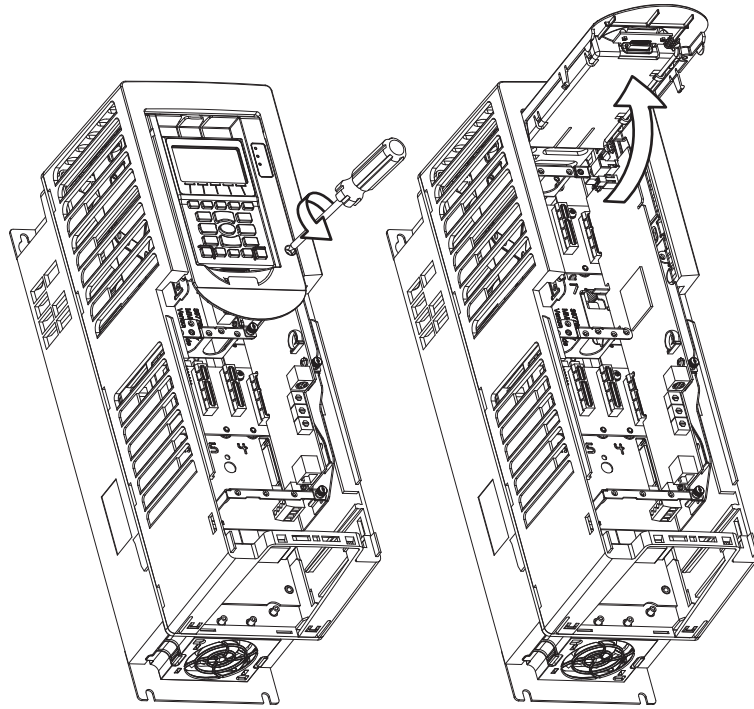

### Remove the Drive Cover for Frames 6 and 7

To remove the drive cover for PowerFlex 753 and 755 frames 6 and 7 drives, follow these steps.

1. Loosen the door screws.
2. Gently pry the door open and remove the door.

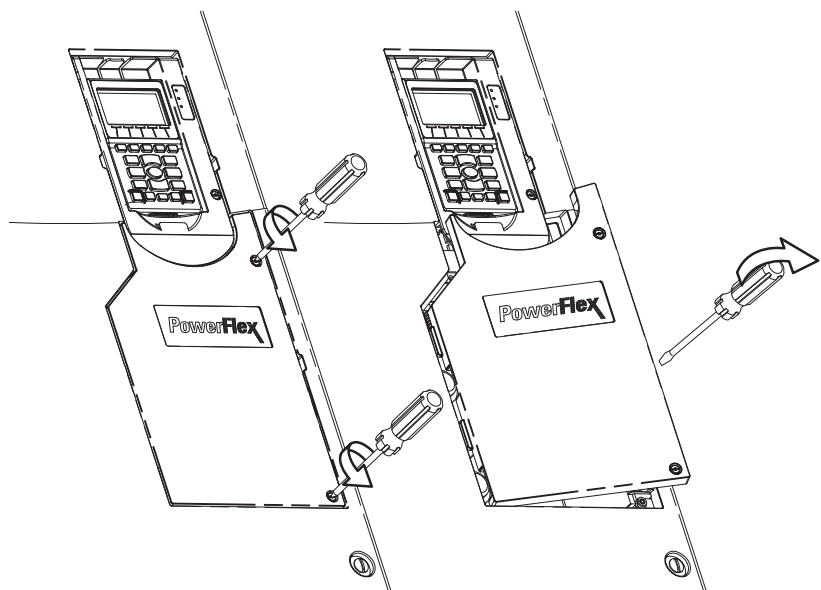

3. Lift the human interface module (HIM) cradle.
  - a. Loosen the retention screw.

b. Lift the cradle until the latch engages.

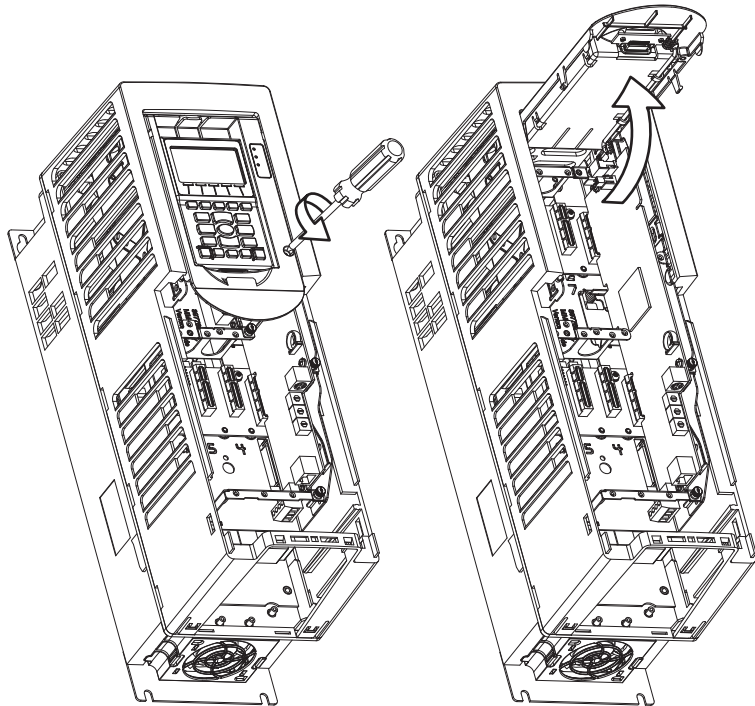

### **Remove the Drive Cover for Frames 8...12**

To remove the drive cover for PowerFlex 755 AC drives and PowerFlex 755T drive products, frame 8...12, follow these steps.

1. Remove the top screws.
2. Loosen the bottom screws.
3. Remove the right front cover.

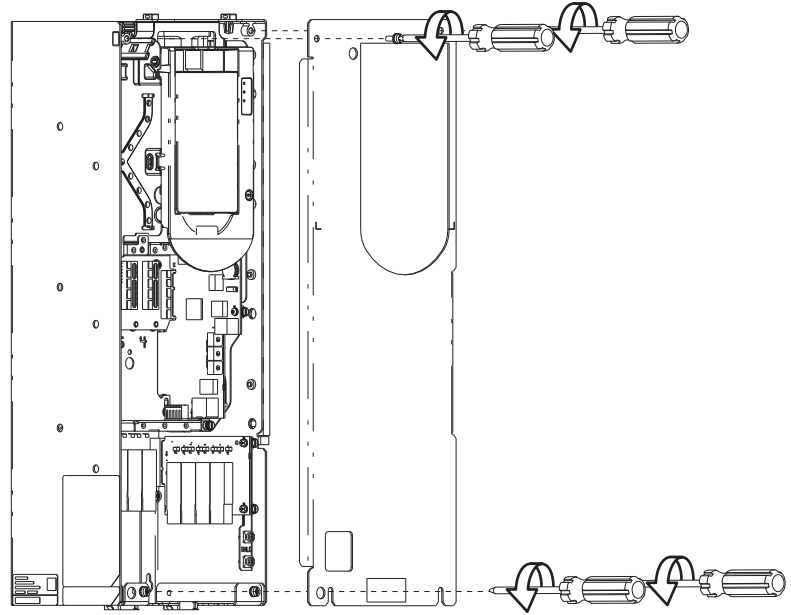

4. Loosen the retention screw.
5. Lift the cradle until the latch engages.

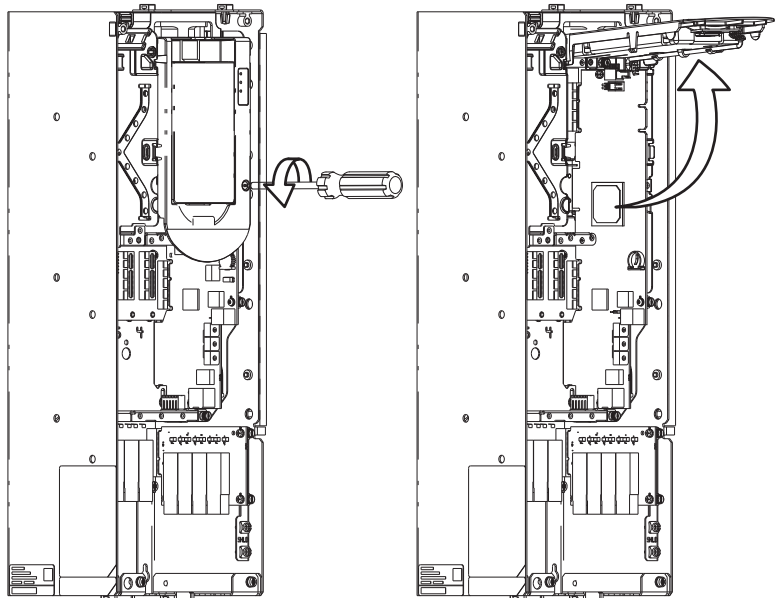

## Configure the Hardware

The ATEX option module can be used in two different configurations:

- ATEX option module and 11-Series I/O option module that is used **without** an additional safety option module. See [page 23](#).
- ATEX option module and 11-Series I/O option module that is used **with** an additional safety option module, such as a Safe Torque Off (catalog number 20-750-S) or Safe Speed Monitor (catalog number 20-750-S1) option module. See [page 24](#).

### S1 Switch Location



**ATTENTION:** Hazard of electric shock exists. Do not remove the insulation wrapper from the ATEX option module. Removal of the insulation wrapper can cause an electric shock hazard, and can cause damage to the drive.

See [Figure 3](#) for the location of the S1 switches on the ATEX option module:

- S1-1 is the safety configuration switch.
- S1-2 is the thermal sensor switch.

**Figure 3 - ATEX Option Module S1 Switch Location**

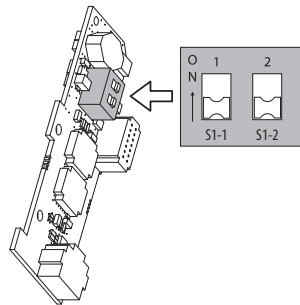

In this diagram, the ATEX option module is shown without the insulation wrapper. **Do not** remove the insulation wrapper from the ATEX option module.

## Safety Enable Jumper Locations

See [Figure 4](#) for the location of the safety enable jumper on the main control board of the PowerFlex 750-Series drives and 755T drive products.

---

**IMPORTANT** PowerFlex 755 floor mount Frame 8 drives and larger do not have a safety enable jumper.

---

**Figure 4 - Safety Enable Jumper Locations on the Main Control Board**

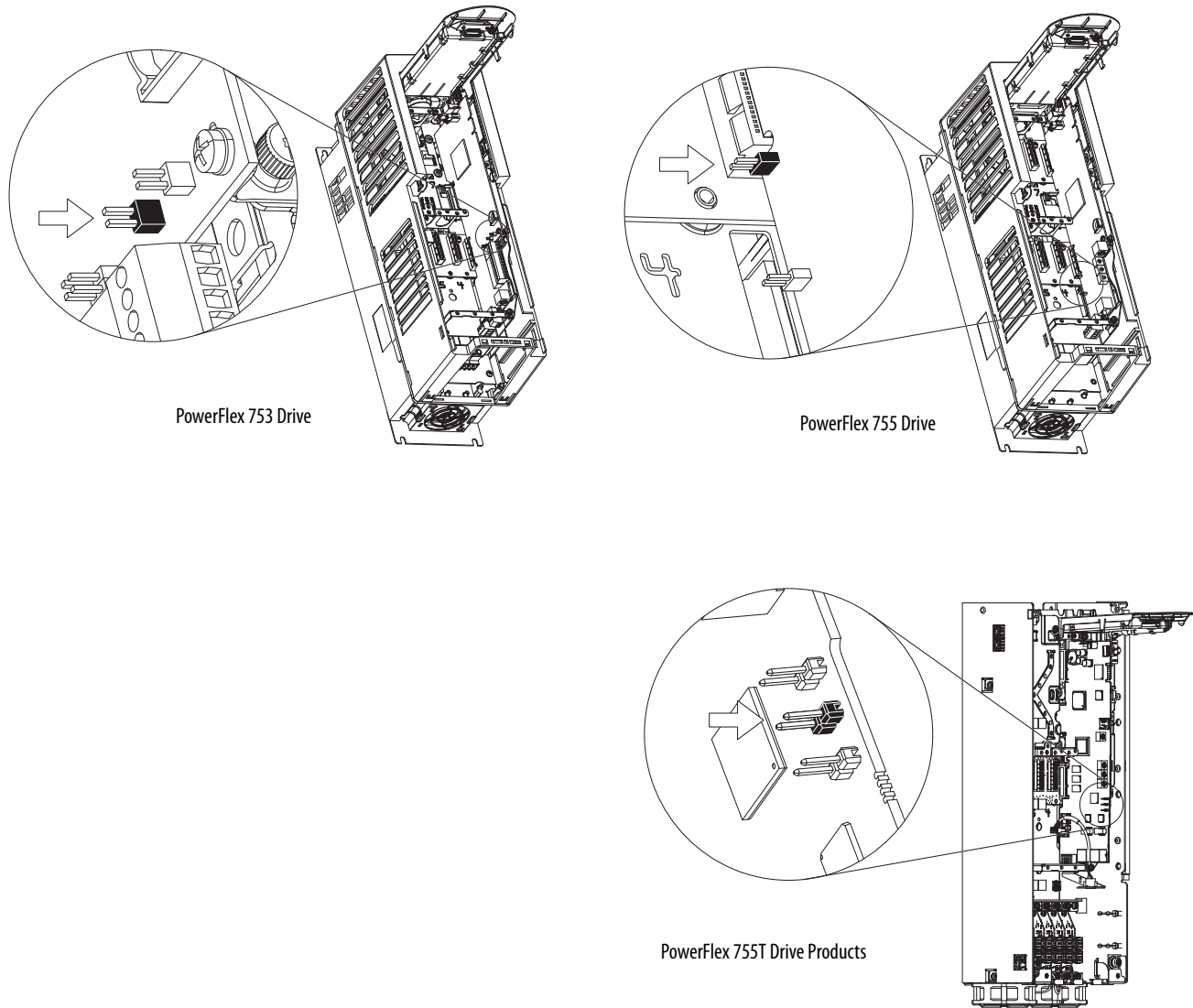

## ATEX Option Module and 11-Series I/O Option Module without a Safety Option Module

To configure the ATEX option module with 11-Series I/O option module for use without a Safe Torque Off (catalog number 20-750-S) or Safe Speed Monitor (catalog number 20-750-S1) option module, follow these steps.

1. Set switch S1-1 to ON.
2. Set switch S1-2 for Thermostat mode or PTC mode.

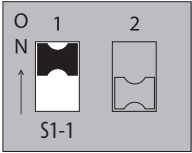
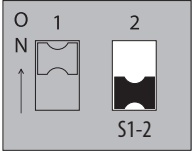
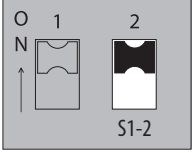
Switch	Setting	Description
S1-1	ON 	Configures the ATEX option module for use without an additional safety option module.
S1-2	OFF 	Configures the ATEX option module for Thermostat mode, over-temperature monitoring. Can be used with PTC-type thermal sensors if short-circuit monitoring is not needed.
	ON 	Configures the ATEX option module for PTC mode. Provides both over-temperature and short-circuit monitoring.

3. Install the safety enable jumper on the main control board.

**IMPORTANT** The default setting of the safety enable jumper = installed.  
For this step, verify that the safety enable jumper is **installed**.

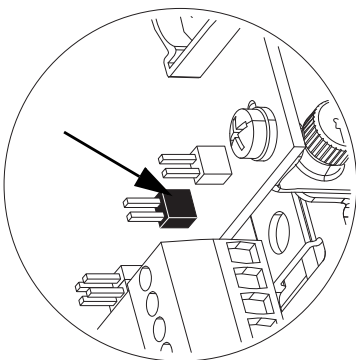

PowerFlex 753 Drive

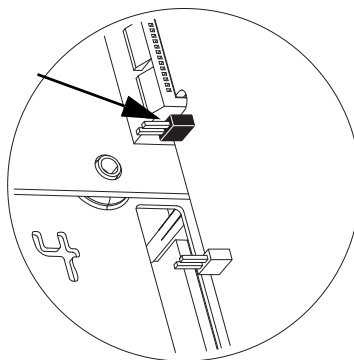

PowerFlex 755 Drive

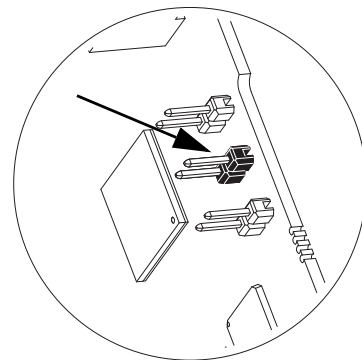

PowerFlex 755T Drive Products

## ATEX Option Module and 11-Series I/O Option Module with a Safety Option Module

To configure the ATEX option module with 11-Series I/O option module for use with a Safe Torque Off (catalog number 20-750-S) or Safe Speed Monitor (catalog number 20-750-S1) option module, follow these steps.

1. Set switch S1-1 to OFF.
2. Set switch S1-2 for Thermostat mode or PTC mode.

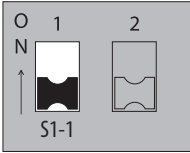
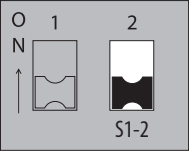
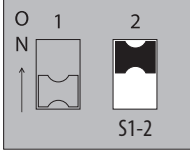
Switch	Setting	Description
S1-1	OFF 	Configures the ATEX option module for use with an additional safety option module.
S1-2	OFF 	Configures the ATEX option module for Thermostat mode, over-temperature monitoring. Can be used with PTC-type thermal sensors if short-circuit monitoring is not needed.
	ON 	Configures the ATEX option module for PTC mode. Provides both over-temperature and short-circuit monitoring.

3. Slide the safety enable jumper off the pins on the main control board.

**IMPORTANT** The default setting of the safety enable jumper = installed.  
For this step, verify that the safety enable jumper is **removed**.

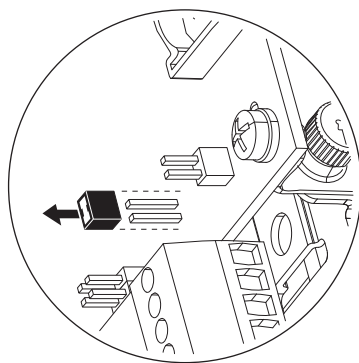

PowerFlex 753 Drive

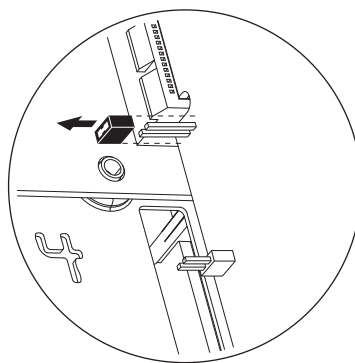

PowerFlex 755 Drive

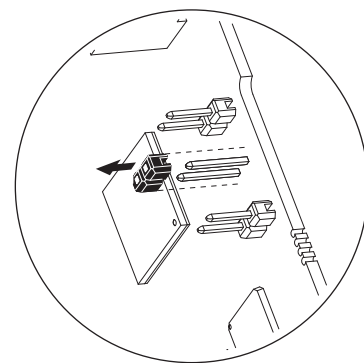

PowerFlex 755T Drive Products



Configuration of the safety enable jumper on the main control board is a requirement of each safety option module. For more information on these requirements, see the specific option module user manual:

- PowerFlex Safe Torque Off User Manual, publication [750-UM002](#)
- Safe Speed Monitor Option Module for PowerFlex 750-Series AC Drives Safety Reference Manual, publication [750-RM001](#)

## Assemble the ATEX and 11-Series I/O Option Modules

After the S1 switches and safety enable jumper are set for your application, join the ATEX option module with the 11-Series I/O option module.

---

**IMPORTANT** Verify that the ATEX function switches are configured correctly for your application before mounting on the 11-Series I/O option module. Once the module is snapped into place, the switches are no longer accessible.

---

1. Align the stand-off pins and the 20-pin connector.

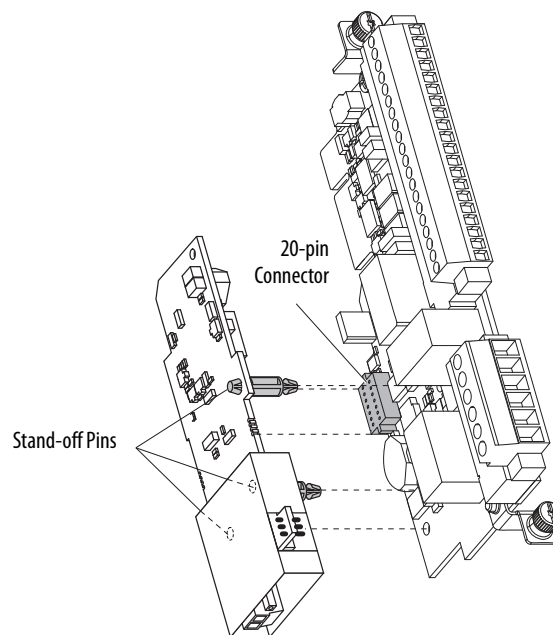

2. Pass the tips of the standoff pins through both boards so that the tip completely expands.

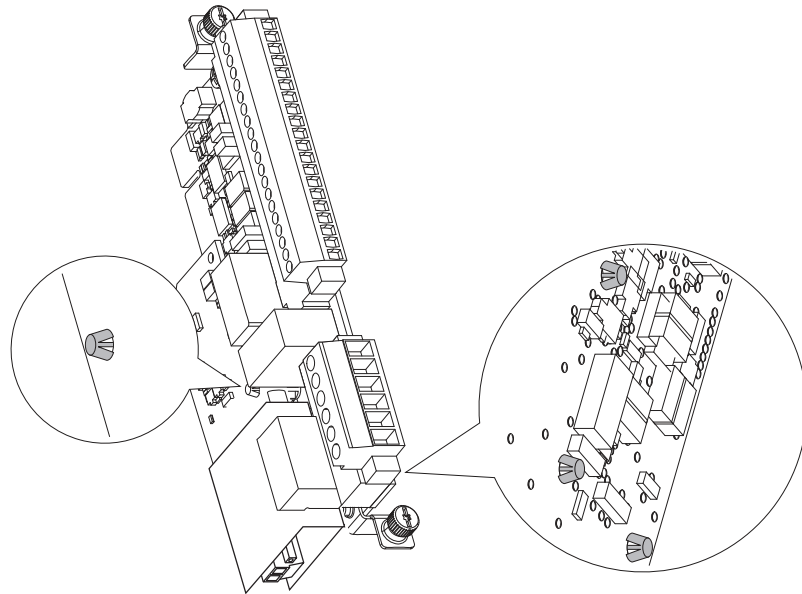

## Connect the Thermal Sensor Wires

Connect the thermal sensor wires to the removable terminal block of the ATEX option module.

20-750-ATEX

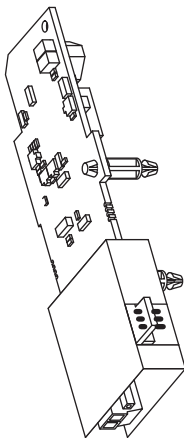

**Table 2 - ATEX Terminal Designations**

	Terminal	Name	Description	Related Parameter
	ATEX+	ATEX input (+)	Motor protection device input.	Parameter 41 [ATEX Sts] See <a href="#">Parameter 41 [ATEX Sts]</a> on <a href="#">page 39</a> .
	ATEX-	ATEX input (-)	Thermostat or PTC-type device. Polarity can be ignored.	

## Cabling Requirements

Follow these requirements for thermal sensor wiring to the removable terminal block of the ATEX option module:

- Use cable duct, conduit, armored cable, or other means to help protect the thermal sensor wires from damage.
- Use shielded, twisted-pair cable.

## Installation Requirements

Installation must meet the radio frequency (RF) emission compliance and installation requirements that are outlined in the installation instructions:

- PowerFlex 750-Series AC Drives Installation Instructions, publication [750-IN001](#).
- PowerFlex 750-Series Products with TotalFORCE Control Installation Instructions, publication [750-IN100](#).
- PowerFlex 755TM IP00 Open Type Kits Installation Instructions, publication [750-IN101](#).

## Install the ATEX Option Module Assembly

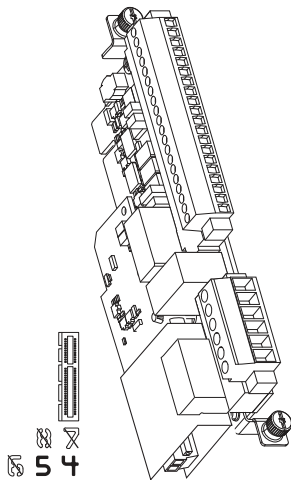

To install the ATEX option module with 11-Series I/O option module assembly in the drive, follow these steps.

1. Remove power from the drive and verify that the voltage on the bus capacitors has discharged.



**ATTENTION:** To avoid an electric shock hazard, verify that the voltage on the bus capacitors has discharged completely before performing any service.

**Frames 1...7:** Measure the DC bus voltage at the power terminal block by measuring between the +DC and -DC terminals or between the +DC and -DC test points if equipped. Also measure between the +DC terminal or test point and the chassis and between the -DC terminal or test point and the chassis. The voltage must be zero for all three measurements.

**Frames 8...12:** Measure the DC bus voltage at the DC+ and DC- test point sockets on the front of the power module.

For the location of the terminal block and test point sockets, see the manual for your drive:

- PowerFlex 750-Series AC Drives Installation Instructions, publication [750-IN001](#)
- PowerFlex 750-Series Products with TotalFORCE Control Installation Instructions, publication [750-IN100](#)
- PowerFlex 755TM IP00 Open Type Kits Installation Instructions, publication [750-IN101](#)

2. Route the thermal sensor wires that are attached to the ATEX removable terminal block under the lower mounting bracket.

**TIP** Leave enough length in the cable so that you can remove the option module in the future, if needed.

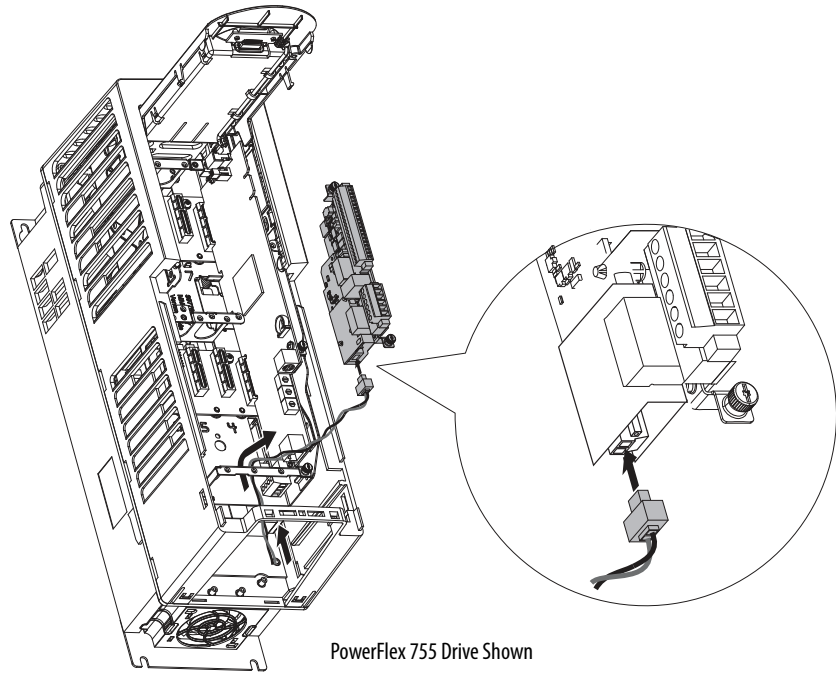

3. Plug in the removable terminal block and secure the screws before installing the assembly on the backplane.

4. Firmly press the 11-Series I/O option module edge connector into port 4 or port 5.

---

**IMPORTANT** The ATEX option module that is mounted on an 11-Series I/O option module can be installed only in drive ports 4 or 5.

---

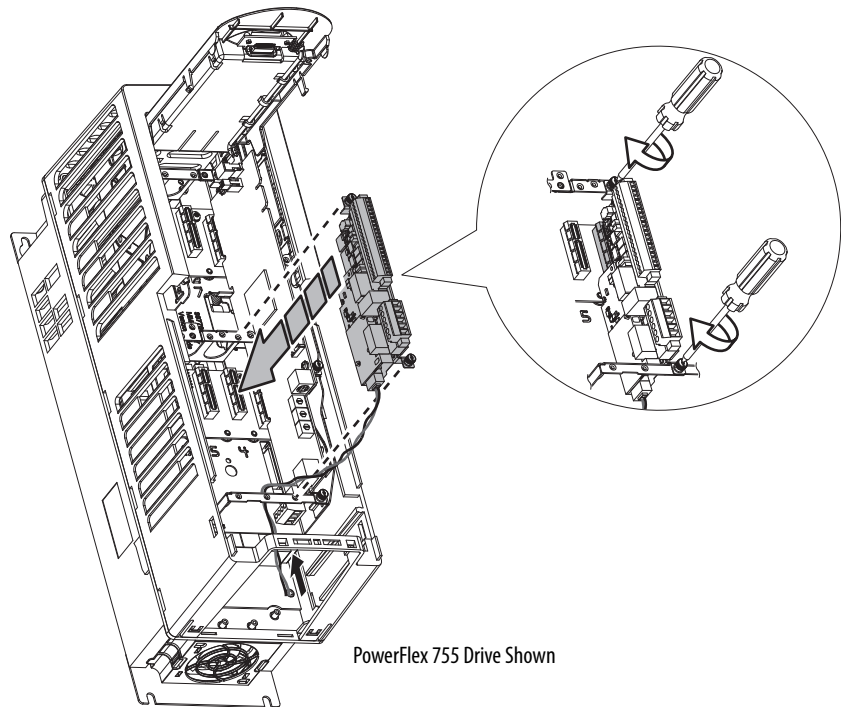

5. Tighten the top and bottom retaining screws:
  - Recommended torque = 0.45 N•m (4.0 lb•in)
  - Recommended screwdriver = T15 Hexalobular



---

**IMPORTANT** Do not overtighten the retaining screws.

---

## Safe Torque Off Option Wiring

The ATEX option module with 11-Series I/O option module can be used with the Safe Torque Off (catalog number 20-750-S) option module. For information about the Safe Torque Off option module, see the PowerFlex Safe Torque Off User Manual, publication [750-UM002](#).



**WARNING:** Risk of Explosion.

If any changes are made to an installed system, the operation of that system must be verified. These changes include installation, removal, or modification of ATEX or functional safety options. Failure to verify that the operation of a completed installation can result in a safety system that does not function correctly. See [Verify Operation on page 33](#).

**IMPORTANT** When a safety option is installed with the ATEX option, you must wire the EnC and EnNO dry contacts.

[Figure 5](#) describes the wiring of the 11-Series I/O option module with the Safe Torque Off option module.

**Figure 5 - Connecting the ATEX Option with a Safe Torque Off Option**

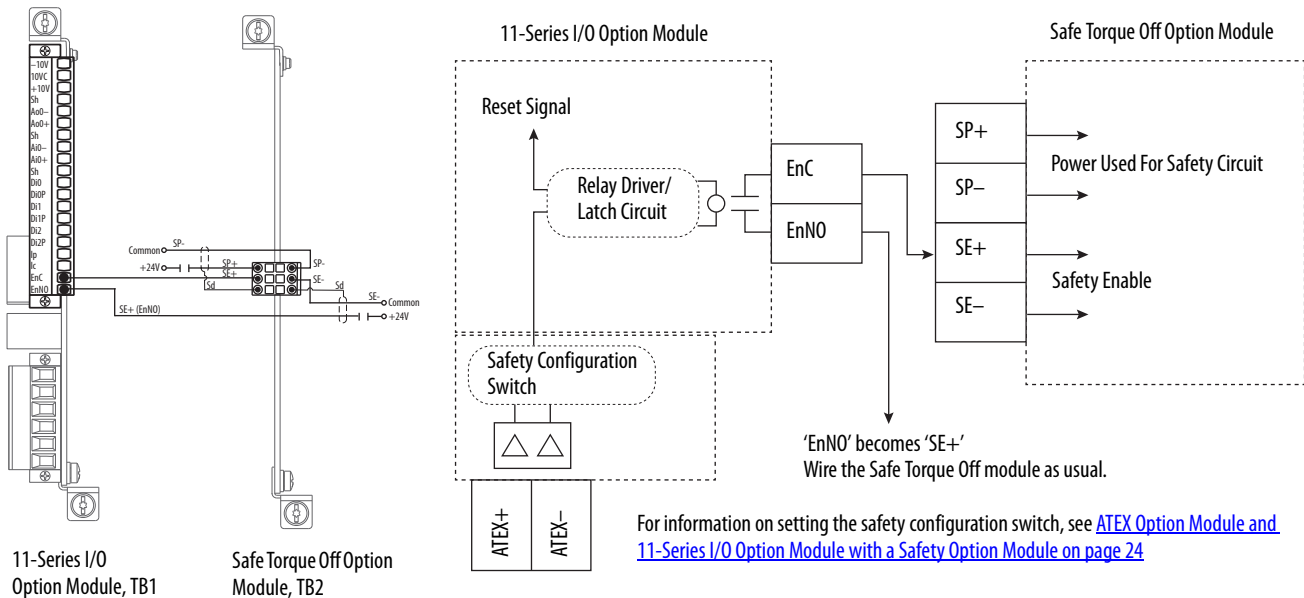

### Operating Principle

The dry contact on the 11-Series I/O option module interrupts the safe enable input (SE+) on the Safe Torque Off option module. The maximum SIL capability of the ATEX function is SIL 1. The maximum SIL capability of the equipment that uses the Safe Torque Off option module remains the same.

## Safe Speed Monitor Option Wiring

The ATEX option module with 11-Series I/O option module can be used with the Safe Speed Monitor (catalog number 20-750-S1) option module. For information about the Safe Speed Monitor option module, see the Safe Speed Monitor Option Module for PowerFlex 750-Series AC Drives Safety Reference Manual, publication [750-RM001](#).



**WARNING:** Risk of Explosion.

If any changes are made to an installed system, the operation of that system must be verified. These changes include installation, removal, or modification of ATEX or functional safety options. Failure to verify that the operation of a completed installation can result in a safety system that does not function correctly. See [Verify Operation on page 33](#).

**IMPORTANT** When a safety option is installed with the ATEX option, you must wire the EnC and EnNO dry contacts.

[Figure 6](#) describes the wiring of the 11-Series I/O option module with the Safe Speed Monitor option module.

**Figure 6 - Connecting the ATEX Option with a Safe Speed Monitor Option**

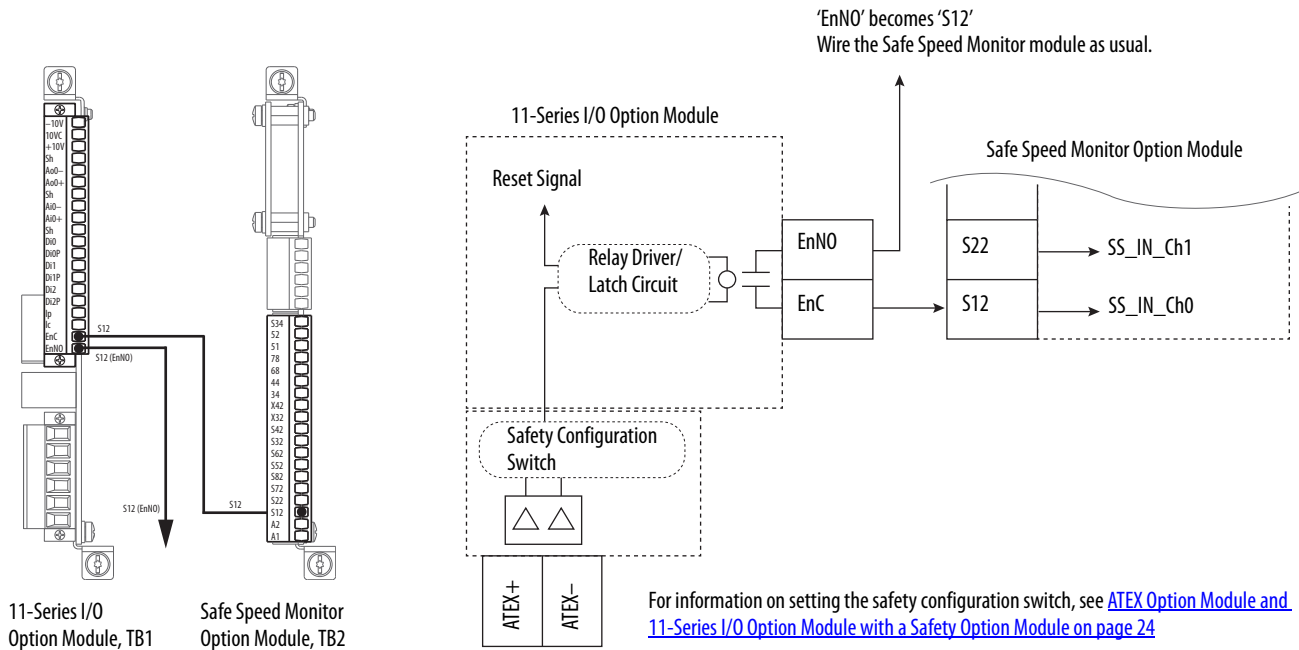

For information on setting the safety configuration switch, see [ATEX Option Module and 11-Series I/O Option Module with a Safety Option Module on page 24](#)

### Operating Principle

The dry contact on the 11-Series I/O option module interrupts the safe stop input channel 0 (SS\_IN\_CH0 pin S12) on the Safe Speed Monitor option module. The maximum SIL capability of the ATEX function is SIL 1. The maximum SIL capability of the equipment that uses the Safe Speed Monitor option module remains the same.

### Safe Speed Monitor (SSM) Configuration Requirements



**WARNING:** Risk of Explosion.

You must set parameter 44 [Safe Stop Input] and parameter 45 [Safe Stop Type] to one of the options that are defined in this section.

Setting the parameters to a different option can result in an explosion.

The following Safe Speed Monitor parameters enable the ATEX function to immediately remove power to the motor in case of an ATEX fault condition.

You **must** set parameter 44 [Safe Stop Input] to one of these options:

- 1 - 2NC
- 3 - 1NC+1NO

You **must** set parameter 45 [Safe Stop Type] to one of these options:

- 0 - Torque Off
- 3 - Trq Off NoCk

## Reset the Drive after an SSM Fault Detection

The reset sequence depends on the configuration of the reset type for the SSM. To reset the drive, follow these steps.

1. Clear the ATEX fault condition.
2. Issue a clear fault command.
3. Cycle the safety device that is wired to both channels of the safe stop input so that both SS\_IN\_CHx inputs are cycled low to high.

If the SSM reset type is 'automatic', the drive is fully reset. Manual and Manual-monitored modes require the reset input to the SSM card to be either high, or cycled before the drive is fully reset.

## Interface Without a Safety Option

The ATEX option module with the 11-Series I/O option module can be used without a safety option with the safety signal on the backplane. The EnC and EnNO contacts can be left unwired.



## Verify Operation

Topic	Page
Description of Functionality	33
Motors with Thermostatic Switches	34
Motors with Positive Temperature Coefficient (PTC) Devices	35
Functional Proof Testing without a Test Fixture	36

Test the safety function for proper operation after initial installation and after the drive system is modified. We recommend annual functional testing during regular maintenance intervals.



**WARNING:** Risk of Explosion.

If any changes are made to an installed system, the operation of that system must be verified. These changes include installation, removal, or modification of ATEX or functional safety options. Failure to verify that the operation of a completed installation can result in a safety system that does not function correctly. See [Verify Operation on page 33](#).

**IMPORTANT** For installation of PowerFlex 755T drive products (frame 8 and larger) check your drive firmware release notes for known anomalies and verify that there are no safety-related anomalies.

### Description of Functionality

The ATEX option module with 11-Series I/O option module provides ATEX functionality for ATEX motors with thermostat contacts or PTC-type devices. The module removes power from the gate firing circuits of the drive output power devices (IGBTs) when the temperature circuit in the motor indicates that the motor temperature is too high.

## Motors with Thermostatic Switches

Thermostatic switches are arranged in series throughout the motor. Typically there is a switch, or a pair of switches, in each motor turn. Each switch opens when the local temperature is too high. The ATEX option module with 11-Series I/O option module can detect an over-temperature event anytime the circuit between the terminals is open.

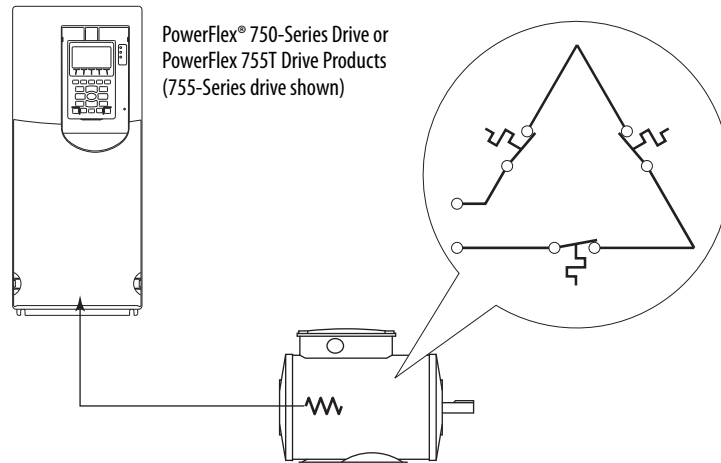

## Functional Proof Testing for Systems with Thermostat Contacts

Build a test fixture with a switch, a spare terminal plug (see [Catalog Numbers for Spare Terminal Plugs on page 7](#)), and this schematic.

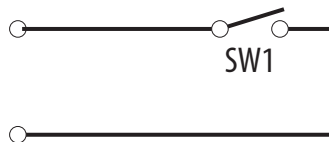

To perform the thermostat contacts functional proof test, follow these steps.

1. Close SW1.
2. Run the drive.
3. Open SW1.

If the system is working correctly, the drive faults due to a motor over-temperature event detection. See [ATEX Fault Descriptions on page 40](#).

4. If a safety option is present, check parameter 933 [Start Inhibits] and verify that bit 2 [Enabled] and bit 7 [Safety] are set to high.

## Motors with Positive Temperature Coefficient (PTC) Devices

PTC-type devices are arranged in series throughout the motor. The resistance of each PTC goes up as the motor temperature rises. The ATEX option module with 11-Series I/O option module can detect an over-temperature event. See [General Specifications on page 43](#) for PTC trip resistance thresholds.

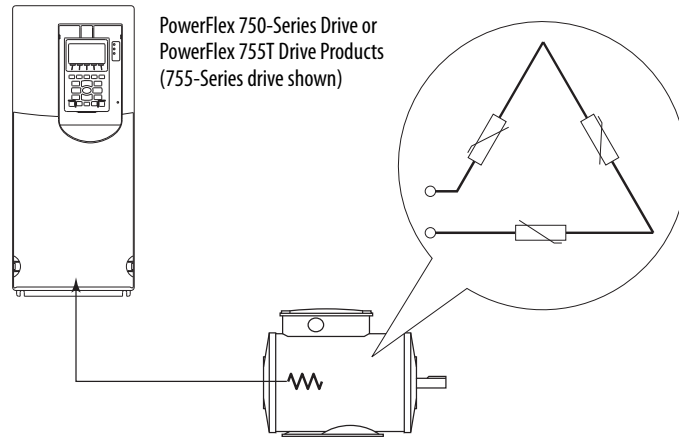

## Functional Proof Testing for Systems with PTC Devices

Build a test fixture with switches, resistors, a spare terminal plug (see [Catalog Numbers for Spare Terminal Plugs on page 7](#)), and this schematic. Resistors must be at least 1/8 W and 5% tolerance.

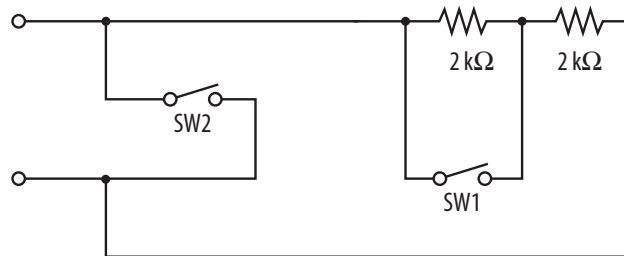

### Over-temperature Functional Proof Test

To perform the PTC device over-temperature functional proof test, follow these steps.

1. Close SW1.
2. Open SW2.
3. Run the drive.
4. Open SW1.

If the system is working correctly, the drive faults due to a motor over-temperature event detection. See [ATEX Fault Descriptions on page 40](#).

5. If a safety option is present, check parameter 933 [Start Inhibits] and verify that bit 2 [Enabled] and bit 7 [Safety] are set to high.

### Short Circuit Functional Proof Test

To perform the PTC device short circuit functional proof test, follow these steps.

1. Close SW1.
2. Open SW2.
3. Run the drive.
4. Close SW2.

If the system is working correctly, the drive faults due to a motor over-temperature event detection.

5. If a safety option is present, check parameter 933 [Start Inhibits] and verify that bit 2 [Enabled] and bit 7 [Safety] are set to high.

## Functional Proof Testing without a Test Fixture

To test the ATEX safety function without a test fixture, follow these steps.

1. Wire the ATEX daughter card to the thermal sensor in the motor.
2. Power up the drive.
3. Verify that no faults exist.
4. Remove power from the drive and verify that the voltage on the bus capacitors has discharged.



**ATTENTION:** To avoid an electric shock hazard, verify that the voltage on the bus capacitors has discharged completely before performing any service.

**Frames 1...7:** Measure the DC bus voltage at the power terminal block by measuring between the +DC and -DC terminals or between the +DC and -DC test points if equipped. Also measure between the +DC terminal or test point and the chassis and between the -DC terminal or test point and the chassis. The voltage must be zero for all three measurements.

**Frames 8...12:** Measure the DC bus voltage at the DC+ and DC- test point sockets on the front of the power module.

For the location of the terminal block and test point sockets, see the manual for your drive:

- PowerFlex 750-Series AC Drives Installation Instructions, publication [750-IN001](#)
- PowerFlex 750-Series Products with TotalFORCE Control Installation Instructions, publication [750-IN100](#)
- PowerFlex 755TM IP00 Open Type Kits Installation Instructions, publication [750-IN101](#)

5. Unplug the ATEX terminal plug from the ATEX daughter board.

6. Power up the drive.  
If the ATEX safety function is operating correctly, an over temperature fault is enunciated.
7. If a safety card is present, check parameter 933 [Start Inhibits] and verify that bit 2 [Enabled] and bit 7 [Safety] are set to high.
8. Remove power from the drive and verify that the voltage on the bus capacitors has discharged (see [step 4](#)).
9. Reinstall the ATEX terminal plug.
10. Power up the drive and verify that the over temperature fault can now be cleared.  
If the SSM option is present, additional steps are required. See [Reset the Drive after an SSM Fault Detection on page 32](#).

**Notes:**

## ATEX Monitoring

Topic	Page
Parameter 41 [ATEX Sts]	39
ATEX Fault Descriptions	40
ATEX Configuration Errors	40
Restart the Drive after an Over-temperature Fault	41

This section describes the parameter 41 [ATEX Sts] bit functionality, the ATEX faults and configuration errors, and how to restart the drive after an over-temperature fault.

### Parameter 41 [ATEX Sts]

Parameter 41 [ATEX Sts] appears in the 11-Series I/O file, Motor PTC group, when the ATEX option module is installed.

This parameter provides the status of the ATEX thermal sensor. If an ATEX fault occurs, the corresponding bits change. When the temperature falls below the trip point, the bits change back to their original settings.

A descriptive fault message is displayed. The fault message can be retrieved from the fault queue after you clear the fault message from the display.

File	Group	No.	Display Name Full Name Description	Values	Read-write	Data Type																																													
11-Series I/O	Motor PTC	41	<b>ATEX Sts</b> ATEX Status  This parameter is not latched and only displays the status of the ATEX thermal sensor. When an ATEX fault is present, the corresponding bit value is 1. When motor temperature is within the optimal range, the bit value is 0. This parameter is available only when an ATEX option module is installed.		RO	16-bit Integer																																													
			<table border="1"> <thead> <tr> <th>Options</th> <th>Reserved</th> <th>PTC Selected</th> <th>Thermostat</th> <th>Reserved</th> <th>Reserved</th> <th>Reserved</th> <th>Reserved</th> <th>Reserved</th> <th>Reserved</th> <th>Reserved</th> <th>Reserved</th> <th>Reserved</th> <th>Voltage Loss</th> <th>Over Temp</th> <th>Short Ckrt</th> <th>ThrmIsnsor OK</th> </tr> </thead> <tbody> <tr> <td>Default</td> <td>0</td> <td>0</td> <td>0</td> <td>0</td> <td>0</td> <td>0</td> <td>0</td> <td>0</td> <td>0</td> <td>0</td> <td>0</td> <td>0</td> <td>0</td> <td>0</td> <td>0</td> <td>0</td> </tr> <tr> <td>Bit</td> <td>15</td> <td>14</td> <td>13</td> <td>12</td> <td>11</td> <td>10</td> <td>9</td> <td>8</td> <td>7</td> <td>6</td> <td>5</td> <td>4</td> <td>3</td> <td>2</td> <td>1</td> <td>0</td> </tr> </tbody> </table> <p>0 = Condition False 1 = Condition True</p> <p>Bit 0 "ThrmIsnsor OK" – Thermal sensor is Ok.                      Bit 1 "Short Ckrt" – Short circuit fault that is detected by thermal sensor.                      Bit 2 "Over Temp" – Over temperature fault that is detected by thermal sensor.                      Bit 3 "Voltage Loss" – Voltage loss fault has taken place on ATEX board.                      Bit 13 "Thermostat" – Thermostat input has been selected.                      Bit 14 "PTC Selected" – PTC input has been selected.</p>	Options			Reserved	PTC Selected	Thermostat	Reserved	Reserved	Reserved	Reserved	Reserved	Reserved	Reserved	Reserved	Reserved	Voltage Loss	Over Temp	Short Ckrt	ThrmIsnsor OK	Default	0	0	0	0	0	0	0	0	0	0	0	0	0	0	0	0	Bit	15	14	13	12	11	10	9	8	7	6	5
Options	Reserved	PTC Selected	Thermostat	Reserved	Reserved	Reserved	Reserved	Reserved	Reserved	Reserved	Reserved	Reserved	Voltage Loss	Over Temp	Short Ckrt	ThrmIsnsor OK																																			
Default	0	0	0	0	0	0	0	0	0	0	0	0	0	0	0	0																																			
Bit	15	14	13	12	11	10	9	8	7	6	5	4	3	2	1	0																																			

## ATEX Fault Descriptions

Table 3 contains a list of ATEX-specific faults, a description, and the corrective action (where applicable).

**Table 3 - ATEX Faults, Descriptions, and Actions**

Event No. <sup>(1)</sup>	Fault/Alarm Text	Type	Fault Action <sup>(2)</sup>	Description/Corrective Action
xx011	PTC Over Temp	Resettable fault	Coast	An over-temperature condition has been detected in the motor, or the sensor path has been broken.
xx012	PTC ShortCircuit			A short circuit condition has been detected in the sensor path. If the fault is unable to be cleared, make sure the thermal sensor that is connected is a PTC-type and not thermostatic.
xx013	ATX VoltageLoss			Possible hardware damage. A short in the motor to the thermal sensor. An excess of electromagnetic compatibility (EMC) noise due to improper grounding/shielding.
xx014	ThermostatOvrTmp			An over-temperature condition has been detected in the motor, or the sensor path has been broken.

(1) xx indicates the port number where the ATEX option module is installed.

(2) These faults initiate the ATEX function (uncontrolled stop).

## ATEX Configuration Errors

Table 4 shows an example of the device conflict text. A conflict can be enunciated under these conditions:

- During power-up, when the ATEX safety configuration switch is set improperly.
- If the ATEX option module with the 11-Series I/O option module is installed in a slot other than 4 or 5.

**Table 4 - ATEX Configuration Errors**

Device Conflict Text	Description/Action
X Port 06	The ATEX option module and 11-Series I/O option module is installed in an unsupported port.
X Port 06 'Safe Speed Montr'	The safety configuration switch (S1-1) is set to 'ON', and a safety option is present.



## Restart the Drive after an Over-temperature Fault

The drive enters a stop condition and stops current flow to the motor when an over-temperature condition is sensed in the motor.

To restart the drive, follow these steps.

1. To acknowledge the fault, press the Clear soft key.

The fault information is removed so that you can use the HIM.

2. Fix the condition that caused the fault.

The cause must be corrected before the fault can be cleared.

3. Clear the fault by one of these methods:

- Press Stop (stops the drive)
- Cycle drive power
- Select the Clear soft key on the HIM Diagnostic folder Faults menu

4. Perform any reset sequence that is required by any other installed options, such as a Safe Speed Monitor option module.

5. Issue a valid start command to the drive.

**TIP** For more information on faults and how to restart the drive, see the troubleshooting section in the manual for your drive:

- PowerFlex 750-Series AC Drives Programming Manual, publication [750-PM001](#)
- PowerFlex Drives with TotalFORCE Control Programming Manual, publication [750-PM100](#)

**Notes:**

## Specifications and Certifications

Topic	Page
General Specifications	43
11-Series I/O Option Module Terminal Block Specifications	43
Environmental Specifications	44
Certifications	45

This appendix provides specifications for the PowerFlex® ATEX option module with the 11-Series I/O option module.

### General Specifications

This table provides general specifications.

Attribute	Value
Safety integrity level	SIL 1 per IEC 61508 (see <a href="#">Safety Data on page 44</a> )
Conductor type	Shielded twisted-pair cable, max length 150 m (492 ft)
Conductor size <sup>(1)</sup>	0.3...2.5 mm <sup>2</sup> (28...14 AWG)
Strip length	6.0 mm (0.24 in.)
Screwdriver blade	DIN 5264
PTC over-temperature trip resistance	>3.2 kΩ
PTC short circuit trip resistance	<100 Ω
PTC receiver ckt	IEC 60947-8 or EN 60947-8 compatible

(1) See the Industrial Automation Wiring and Grounding Guidelines, publication [1770-4.1](#).

### 11-Series I/O Option Module Terminal Block Specifications

This table provides wire size, torque, and wire strip length for the 11-Series I/O option module.

11-Series I/O Option Module Terminal Block	Terminal Type	Wire Size Range mm <sup>2</sup> (AWG)		Torque N·m (lb·in)		Strip Length mm (in.)
		Max	Min	Max	Recommended	
TB1	Screw terminals	2.5 (14)	0.3 (28)	0.25 (2.2)	0.2 (1.8)	6 (0.24)
	Tension clamp terminals	2.5 (14)	0.13 (26)	N/A		10 (0.39)
TB2	Screw terminals	4.0 (12)	0.25 (24)	0.5 (4.4)	0.4 (3.5)	7 (0.28)
	Tension clamp terminals	4.0 (12)	0.25 (24)	N/A		10 (0.39)

## Safety Data

The PFD and PFH values in [Table 5](#) were calculated based on equations in IEC 61508. This table shows the worst case calculated values for drive frames 1...10 with a proof test interval of 20 years.

---

**IMPORTANT** A proof test is not defined in this user manual. A proof test interval of 20 years is used for the calculations here.

---

These values show the SIL 1 consumption of the ATEX safety function to be approximately 30%. The safety calculations represent the local ATEX safety path from the input of the ATEX daughter card to the device that disables heat-producing power.

**Table 5 - PFD and PFH for 20-year Proof Test Interval for Frames 1...10**

Attribute	Value
Safety integrity level (SIL)	1
Hardware fault tolerance (HFT)	0
Mission Time (MT)	20
Probability of failure on demand (PFD)	<3.09E-02
Probability of failure per hour (PFH [1/hour])	<3.53E-07

## Environmental Specifications

The installation must comply with all environmental, pollution degree, and drive enclosure rating specifications required for the operating environment.

Category	Specification
Ambient temperature	For detailed information on environmental, pollution degree, and drive enclosure rating specifications, see the technical data publication for your drive: <ul style="list-style-type: none"> <li>• PowerFlex 750-Series AC Drives Technical Data, publication <a href="#">750-TD001</a></li> <li>• PowerFlex 750-Series Products with TotalFORCE Control Technical Data, publication <a href="#">750-TD100</a></li> <li>• PowerFlex 755TM IP00 Open Type Kits Technical Data, publication <a href="#">750-TD101</a></li> </ul>
Storage temperature	
Shock	
Operating	
Packaged for shipment	
Vibration	
Operating	
Packaged for shipment	
Sinusoidal load	
Random secured	
Surrounding environment	



**ATTENTION:** A failure to maintain specified ambient temperature can result in a failure of the safety function.

---

**Table 6 - Environmental Pollution Degree Description According to EN 61800-5-1**

<b>Surrounding Environment Pollution Degree</b>	<b>Conductive Contamination Allowed by Pollution Degree</b>	<b>Acceptable Enclosures</b>
Pollution degree 1 and 2.	No possibility of conductive dust.	All enclosures are acceptable.
Pollution degree 3 and 4.	A possibility of conductive dust is allowed.	Enclosure that meets or exceeds IP54, NEMA/UL Type 12 is required.

## Certifications

The ATEX option module (catalog number 20-750-ATEX) together with the 11-Series I/O option module (catalog numbers 20-750-1132D 2R, 20-750-1133C-1R2T, or 20-750-1132C-2R) are certified to be in conformity with the legislation and standards that are listed in this table.

<b>Certification<sup>(1)</sup></b>	<b>Legislation/Standard/Certificate</b>
cULus (U.S. and Canada) <sup>(2)</sup>	UL 508C (U.S.); C22.2 No.14 (Canada); and UL 61800-5-1
CE (Europe)	Low Voltage Directive (2014/35/EU) EN 61800-5-1 EMC Directive (2014/30/EU) EN 61800-3 ATEX Directive (2014/34/EU) EC-Type-Examination Certificate Number: TÜV 17 ATEX 7990 X EN 50495
Regulatory Compliance Mark	Radiocommunications Act: 1992 Radiocommunications (EMC) Standard: 2012 Radiocommunications Labeling (EMC) Notice: 2008 IEC 61800-3
KCC (Korea)	Radio Waves Act: Article 58-2

(1) Certification information can be viewed at <http://www.rockwellautomation.com/global/certification/overview.page>.

(2) Underwriters Laboratories Inc. has not evaluated the ATEX option module for functional safety.

**Notes:**

## Numerics

20-750-1132C-2R 7  
 20-750-1132D-2R 7  
 20-750-1133C-1R2T 7  
 20-750-ATEX 7  
 20-750-S 21  
 20-750-S1 21

## A

### ATEX

circuitry 12  
 configuration errors  
   X Port 06 40  
   X Port 06 'Safe Speed Montr' 40  
 installation example 11

### ATEX directive 2014/34/EU

Category 2 9  
 GD 9  
 Group II 9

### ATEX option module

configure for PTC mode 24  
 configure for thermostat mode 24  
 insulation wrapper 21  
 used with a safety option module 24  
 used without a safety option module 23

## B

### backplane 32

### bus voltage test points

frames 1...7 27, 36  
 frames 8...10 27, 36  
 verify discharge 27, 36

## C

### cabling requirements

thermal sensor 26

### catalog numbers

11-Series I/O option modules 7  
 ATEX option module 7  
 Safe Speed Monitor option module 21  
 Safe Torque Off option module 21  
 spare terminal plug kits 7

### configuration errors

X Port 06 40  
 X Port 06 'Safe Speed Montr' 40

## D

### drive enclosure rating specifications 44

### drive ports 29

### dry contact 30, 32

### dust 9

## E

### EnC 30, 31, 32

### EnNO 30, 31, 32

### explosion risk 7, 9, 11, 30, 31, 32, 33

### explosive atmosphere 9, 11

## F

### failure analysis 13

### fault descriptions

ATEX-specific faults 40

### fault reset sequence 32

### fault text

ATX VoltageLoss 40  
 PTC Over Temp 40  
 PTC ShortCircuit 40  
 ThermostatOvrTmp 40

### functional proof test

over temperature 35  
 PTC devices 35  
 short circuit 36  
 test fixture for PTC devices 35  
 test fixture for thermostat contacts 34  
 thermostat contacts 34  
 without a test fixture 36

### functional testing 33

### functional tests 16

## G

### gas vapors 9

## H

### hardware fault tolerance 13

## I

### installation environment 44

### installation environments

dust environments 10  
 gas environments 10

### installation example

ATEX 11

## J

### jumper

configure the safety enable 25  
 safety enable 22  
 safety enable installed 23  
 safety enable removed 24

**M****motor**

- ATEX certified 11
- ATEX guidelines 10
- certification nameplate 10
- dust environments 10
- flameproof construction 10
- gas environments 10
- insulation fault 11
- labeled for hazardous areas 10
- nameplates 10
- over-temperature signal 10
- protected by enclosure 10
- thermal sensor 11

**O****option modules**

- safe speed monitor (20-750-S1) 31
- safe torque off (20-750-S) 30

**over-temperature**

- event 34
- functional proof test 35

**P****parameter**

- 41 ATEX Sts 26, 39
- 44 Safe Stop Input 32
- 45 Safe Stop Type 32
- 933 Start Inhibits 34, 35, 36, 37

**PFD** 44**PFH** 44**pollution degree** 44**positive temperature coefficient** 10, 12

- devices 35

**PowerFlex 755T drive products** 5**proof test interval** 44**PTC** 10, 12

- trip resistance 35

**PTC mode** 24**R****radio frequency (RF) emission compliance** 27**reset the drive** 32**resistors** 35**restart the drive** 41**risk**

- assessment 6, 15
- of explosion 11, 30, 31, 32, 33

**S****S1 switches**

- S1-1 21
- S1-2 21

**safe state** 12**safe speed monitor parameters**

- P44 32
- P45 32

**safety**

- analysis 6, 16
- configuration switch (S1-1) 21
- enable jumper 22, 23, 24
  - configure 25
- function test 33
- input signal trigger 13
- reaction time 13
- signal on backplane 32

**shock and vibration** 44**short-circuit functional proof test** 36**SIL 1** 30, 32, 44**SIL capability** 30, 32**SK-R1-SCRWTB-EIO** 7**SK-R1-SPRGTB-EIO** 7**spare terminal plug kits** 7**specifications** 43**stop condition** 41**T****temperature**

- ambient 44
- storage 44

**terminals**

- EnC 12, 30, 31
- EnNO 12, 30, 31

**test**

- safety function 33

**thermal sensor** 11, 16

- cabling requirements 26
- switch (S1-2) 21
- wiring 26

**thermostat contacts**

- functional proof test 34

**thermostat mode** 24**thermostatic switches** 34**U****user manuals**

- safe speed monitor 25
- safe torque off 25

**W****wiring**

- safe speed monitor option module 31
- safe torque-off option module 30
- thermal sensor 26





## Rockwell Automation Support

Use the following resources to access support information.

<b>Technical Support Center</b>	Knowledgebase Articles, How-to Videos, FAQs, Chat, User Forums, and Product Notification Updates.	<a href="https://rockwellautomation.custhelp.com/">https://rockwellautomation.custhelp.com/</a>
<b>Local Technical Support Phone Numbers</b>	Locate the phone number for your country.	<a href="http://www.rockwellautomation.com/global/support/get-support-now.page">http://www.rockwellautomation.com/global/support/get-support-now.page</a>
<b>Direct Dial Codes</b>	Find the Direct Dial Code for your product. Use the code to route your call directly to a technical support engineer.	<a href="http://www.rockwellautomation.com/global/support/direct-dial.page">http://www.rockwellautomation.com/global/support/direct-dial.page</a>
<b>Literature Library</b>	Installation Instructions, Manuals, Brochures, and Technical Data.	<a href="http://www.rockwellautomation.com/global/literature-library/overview.page">http://www.rockwellautomation.com/global/literature-library/overview.page</a>
<b>Product Compatibility and Download Center (PCDC)</b>	Get help determining how products interact, check features and capabilities, and find associated firmware.	<a href="http://www.rockwellautomation.com/global/support/pcdc.page">http://www.rockwellautomation.com/global/support/pcdc.page</a>

## Documentation Feedback

Your comments will help us serve your documentation needs better. If you have any suggestions on how to improve this document, complete the How Are We Doing? form at [http://literature.rockwellautomation.com/idc/groups/literature/documents/du/ra-du002\\_-en-e.pdf](http://literature.rockwellautomation.com/idc/groups/literature/documents/du/ra-du002_-en-e.pdf).

Rockwell Automation maintains current product environmental information on its website at <http://www.rockwellautomation.com/rockwellautomation/about-us/sustainability-ethics/product-environmental-compliance.page>.

Allen-Bradley, PowerFlex, TotalFORCE, Rockwell Automation, and Rockwell Software are trademarks of Rockwell Automation, Inc.

Trademarks not belonging to Rockwell Automation are property of their respective companies.

Rockwell Otomasyon Ticaret A.Ş., Kar Plaza İş Merkezi E Blok Kat:6 34752 İçerenköy, İstanbul, Tel: +90 (216) 5698400

**[www.rockwellautomation.com](http://www.rockwellautomation.com)**

### Power, Control and Information Solutions Headquarters

Americas: Rockwell Automation, 1201 South Second Street, Milwaukee, WI 53204-2496 USA, Tel: (1) 414.382.2000, Fax: (1) 414.382.4444

Europe/Middle East/Africa: Rockwell Automation NV, Pegasus Park, De Kleetlaan 12a, 1831 Diegem, Belgium, Tel: (32) 2 663 0600, Fax: (32) 2 663 0640

Asia Pacific: Rockwell Automation, Level 14, Core F, Cyberport 3, 100 Cyberport Road, Hong Kong, Tel: (852) 2887 4788, Fax: (852) 2508 1846

Publication 750-UM003D-EN-P - March 2017

Supersedes Publication 750-UM003C-EN-P - February 2016

Copyright © 2017 Rockwell Automation, Inc. All rights reserved. Printed in the U.S.A.