









Operating Levers

For use with 802T, 802M, 802MC, 802X, 802XR





Roller Levers

Type	Roller			Cat. No.
	Material	Dia.	Width	
 Non-Adj. Cast Lever 0.75" Radius	Metal	0.75"	0.27"	802T-W9A
 Non-Adj. Cast Lever 1.5" Radius Roller on Front	Nylon	0.75"	0.28"	802T-W1
	Nylon	0.75"	1"	802T-W1H
	Dual Nylon	0.75"	1" each	802T-W1HH
	Steel	0.75"	0.25"	802T-W1A
	Steel	0.75"	0.75"	802T-W1N
	Ball Bearing	0.75"	0.23"	802T-W1B
	Beryllium Copper (Nonsparking)	0.75"	0.28"	802T-W1J
 Non-Adj. Cast Lever 1.5" Radius Roller on Rear	Nylon	0.75"	0.28"	802T-W1E
	Nylon	0.75"	1"	802T-W1D
	Nylon	1.5"	0.28"	802T-W1G
	Steel	0.75"	0.25"	802T-W1F
	Steel	0.75"	0.75"	802T-W1C
	Nylon	0.75"	0.75"	802T-W1M
	 Non-Adj. Steel Lever 2.0" Radius Roller on Front	Nylon	0.75"	0.28"
Nylon		0.75"	1"	802T-W20D
Steel		0.75"	0.25"	802T-W20A
Steel		0.75"	0.75"	802T-W20B
Ball Bearing		0.75"	0.23"	802T-W20C
Beryllium Copper		0.75"	0.28"	802T-W20E
 Non-Adj. Steel Lever 2.0" Radius Roller on Rear		Nylon	0.75"	0.28"
	Nylon	0.75"	1"	802T-W20K
	Steel	0.75"	0.25"	802T-W20L
	Steel	0.75"	0.75"	802T-W20M
	Ball Bearing	0.75"	0.23"	802T-W20N
 Non-Adj. Steel Lever 2 1/8" Radius Roller on Front	Beryllium Copper	0.75"	0.28"	802T-W20P
	Nylon	0.75"	0.75"	802T-W18
 Non-Adj. Steel Lever 2 1/8" Radius Roller on Front	Nylon	0.75"	1"	802T-W18A

Approximate Dimensions—See page 5-133.

Type	Roller			Cat. No.
	Material	Dia.	Width	
 Non-Adj. Steel Lever 2.5" Radius Roller on Front	Nylon	0.75"	0.28"	802T-W25
	Nylon	0.75"	1"	802T-W25D
	Steel	0.75"	0.25"	802T-W25A
	Steel	0.75"	0.75"	802T-W25B
	Ball Bearing	0.75"	0.23"	802T-W25C
 Non-Adj. Steel Lever 2.5" Radius Roller on Rear	Beryllium Copper	0.75"	0.28"	802T-W25E
	Nylon	0.75"	0.28"	802T-W25J
	Nylon	0.75"	1"	802T-W25K
	Steel	0.75"	0.25"	802T-W25L
	Steel	0.75"	0.75"	802T-W25M
 Non-Adj. Steel Lever 3.0" Radius Roller on Front	Ball Bearing	0.75"	0.23"	802T-W25N
	Beryllium Copper	0.75"	0.28"	802T-W25P
	Nylon	0.75"	0.28"	802T-W30
	Nylon	0.75"	1"	802T-W30D
	Steel	0.75"	0.25"	802T-W30A
 Non-Adj. Steel Lever 3.0" Radius Roller on Rear	Steel	0.75"	0.75"	802T-W30B
	Ball Bearing	0.75"	0.23"	802T-W30C
	Beryllium Copper	0.75"	0.28"	802T-W30E
	Nylon	0.75"	0.28"	802T-W30J
	Nylon	0.75"	1"	802T-W30K
 Non-Adj. Steel Lever 3.0" Radius Roller on Rear	Steel	0.75"	0.25"	802T-W30L
	Steel	0.75"	0.75"	802T-W30M
	Ball Bearing	0.75"	0.23"	802T-W30N
	Beryllium Copper	0.75"	0.28"	802T-W30P
	 Adjustable Lever 1.19" to 3" Radius	Nylon	0.75"	0.28"
Nylon		0.75"	1"	802T-W2D
Nylon		1.5"	0.28"	802T-W2A
Steel		0.75"	0.25"	802T-W2B
Ball Bearing		0.75"	0.23"	802T-W2C
Steel		1.4"	0.27"	802T-W2E
Rubber		1.5"	0.5"	802T-W2R
Beryllium Copper		0.75"	0.28"	802T-NX94
 Adjustable Lever 1.19" to 3.5" Radius		Nylon	0.75"	0.28"
	Metal	802T-W17B		
	Nylon	1.5"		802T-W17A

Roller Levers (continued)

Type	Roller			Cat. No.
	Material	Dia.	Width	
 Fork Lever 1.5" Radius	Nylon; L.H. Roller on Front; R.H. Roller on Back	0.75"	0.28"	802T-W4
	Steel; L.H. Roller on Front; R.H. Roller on Back	0.75"	0.25"	802T-W4B
	Nylon; Both Rollers on Front	0.75"	0.28"	802T-W4A
	Nylon; Both Rollers on Rear	0.75"	0.28"	802T-NX115
	Nylon; Both Rollers on Front	0.75"	1"	802T-W4F
	Steel; Both Rollers on Front	0.75"	0.25"	802T-W4C
	Nylon; L.H. Roller on Back; R.H. Roller on Front	0.75"	0.28"	802T-W4D
 Micrometer Adjustment Lever 1.5" Radius	Nylon R.H. Adj.	0.75"	0.28"	802T-W6
	Steel R.H. Adj.	0.75"	0.25"	802T-W6A
	Ball Bearing R.H. Adj.	0.75"	0.23"	802T-W6B
	Nylon L.H. Adj.	0.75"	0.28"	802T-W6C
	Steel L.H. Adj.	0.75"	0.25"	802T-W6D
	Ball Bearing L.H. Adj.	0.75"	0.23"	802T-W6E
	Nylon R.H. Adj.	0.75"	1"	802T-W6F
 Non-Adj. One-Way Lever 1.5" Radius	Nylon	0.75"	0.28"	802T-W7①
	Steel	0.75"	0.25"	802T-W7A①
	Ball Bearing	0.75"	0.23"	802T-W7B①
 Non-Adj. Offset Lever 1.44" Radius Roller on Front	Nylon	0.75"	0.28"	802T-W12②
	Steel	0.75"	0.25"	802T-W12A②
	Bearing Roller	0.75"	0.23"	802T-W12B
 Non-Adj. Offset Lever 1.44" Radius Roller on Rear	Nylon	0.75"	0.28"	802T-W12E
	Steel	0.75"	0.25"	802T-W12F

Roller Levers—Corrosion-Resistant

Type	Material	Roller		Cat. No.
		Dia.	Width	
 1.5" Radius Roller on Front	Type 316 stainless steel roller, roller pin and clamp pin One-piece cast aluminum arm is protected with TUFRAM®③	0.75"	0.25"	802MC-W1A
 1.5" Radius Roller on Rear	Nylon Roller One-piece cast aluminum arm is protected with TUFRAM®③	1.5"	0.28"	802MC-W1G
 Non-Adj. Offset Lever 1.44" Radius Roller on Front	Nylon Roller One-piece cast aluminum arm is protected with TUFRAM®③	0.75"	0.28"	802MC-W12
 Adjustable 1.19"-.3" Radius	Type 316 stainless steel roller, roller pin, clamp pin and adjustable lever arm Block is cast aluminum protected with TUFRAM®③	0.75"	0.25"	802MC-W2B

Approximate Dimensions—See page 5-133.





- ① Do not use on maintained contact limit switches.
- ② When mounted on Plug-In devices, the offset lever provides equivalent cam tracking to the NonPlug-In devices using catalog number 802T-W1 levers.
- ③ TUFRAM is a synergistic coating which combines the advantages of anodizing with a controlled infusion of PTFE for added corrosion resistance.
- ④ The micrometer adjustment roller lever is designed especially for installations where the position of the roller is a critical factor. This lever has a pivoted roller which can be turned laterally. After clamping the lever to the switch shaft, the position of the roller can be precisely adjusted through an arc of 7.5° on either side of the center or straight-line position.

Limit Switches

Operating Levers

For use with 802T, 802M, 802MC, 802X, 802XR



Rod Levers

Type	Material	Dia.	Cat. No.
	Stainless Steel Rod 5" Long	0.13"	802T-W3②
	Stainless Steel Rod 8.5" Long	0.13"	802T-W3B②
	Stainless Steel Rod 12" Long	0.13"	802T-NX50
	Stainless Steel Rod 11.5" Long	0.13"	802T-W3A
	Stainless Steel Rod 14" Long	0.08"	802T-W3F②
	Nylon Rod 12" Long	0.25"	802T-W3C 802T-NX142 ⑤
		0.06"	802T-W5②
	Stainless Steel Rod 5" Long	0.06"	802T-W8①
		0.18"	802T-W14
	Steel Rod 9" Long	0.25"	802T-W16
		Nylon Rod 9" Long	0.25"

Approximate Dimensions—See page 5-133.

- ① Do not use on maintained contact limit switches.
- ② Recommended for use with low operating torque switches.
- ③ Not for use with 802M-NPY5 or 802M-ASY5 type switches.
- ④ TUFGRAM® is a synergistic coating which combines the advantages of anodizing with a controlled infusion of PTFE for added corrosion resistance.
- ⑤ Recommended for high impact applications.

Rod Levers—Corrosion-Resistant

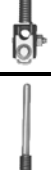
Type	Material	Dia.	Cat. No.
	Type 316 stainless steel rod 5" long Block is cast aluminum protected with TUFGRAM®④	0.13"	802MC-W3
	Type 316 stainless steel rod 11.5" long Block is cast aluminum protected with TUFGRAM®④	0.08"	802MC-W3A
	Nylon Rod 12" long Block is cast aluminum protected with TUFGRAM®④	0.25"	802MC-W3C
	Nylon Rod Only	0.25"	WF25507

Approximate Dimensions [mm (in.)]

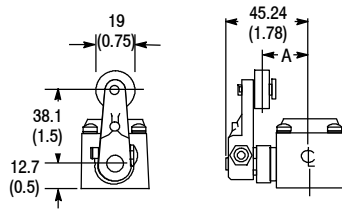

802T-W1C (Dim. A = 0.81");
802T-W1E and 802T-W1F (Dim. A = 1.03")
Shipping Wt. 57g (2oz). (W1C), 1 oz. (W1E),
43g (1.5oz) (W1F)

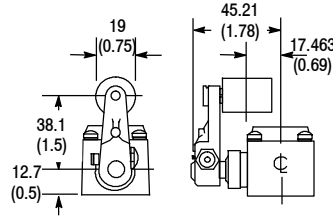

802T-W1D
Shipping Wt. 43g (1.5oz)

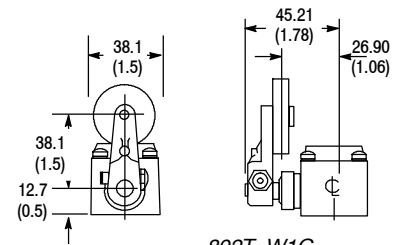

802T-W1G
Shipping Wt. 28g (1oz)

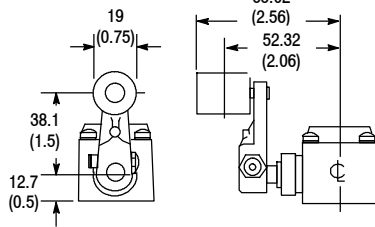

802T-W1H
Shipping Wt. 43g (1.5oz)

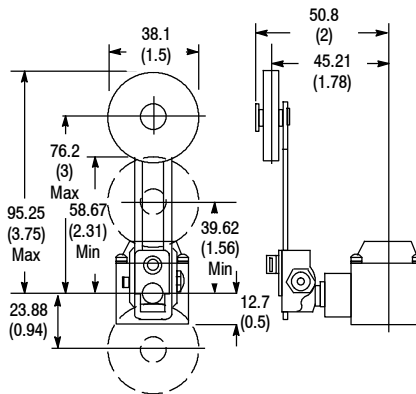

802T-W2A
Shipping Wt. 57g (2oz)

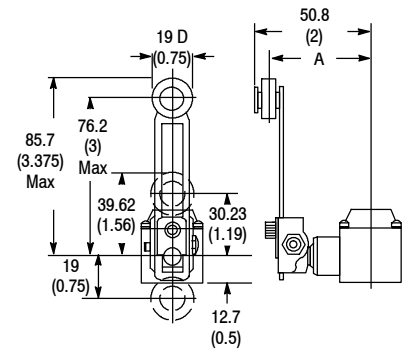

802T-W2 & 802T-W2B (Dim. A = 1.78");
802T-W2C (Dim. A = 1.81")
Shipping Wt. 57g (2oz)

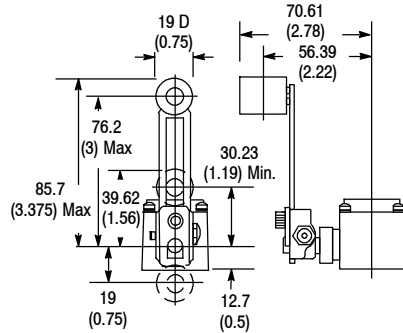

802T-W2D
Shipping Wt. 57g (2oz)

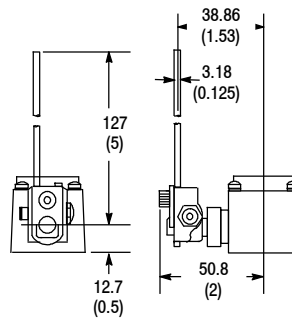

802T-W3
Shipping Wt. 43g (1.5oz)

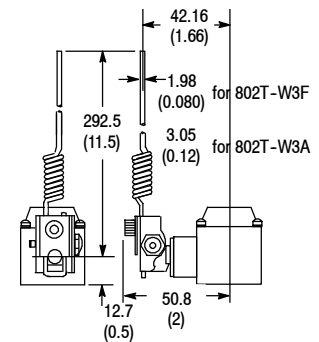

802T-W3A and 802T-W3F
Shipping Wt. 57g (2oz)

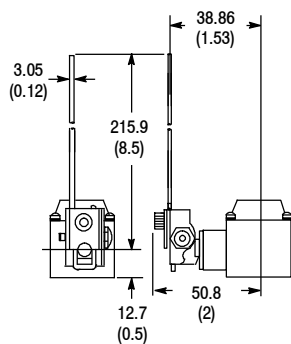

802T-W3B and 802T-W3F
Shipping Wt. 43g (1.5oz)

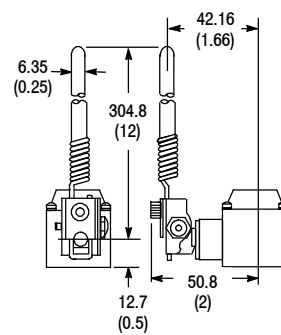

802T-W3C
Shipping Wt. 57g (2oz)

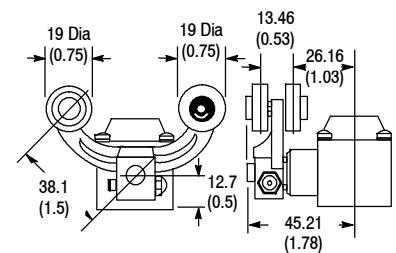

802T-W4 and 802T-W4D
Shipping Wt. 43g (1.5oz) 802T-W4B
Shipping Wt. 57g (2oz)

Approximate Dimensions [mm (in.)] (continued)

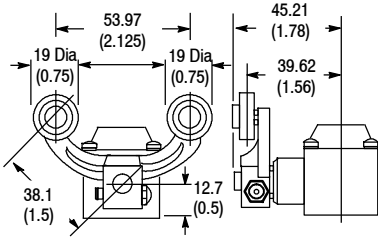

802T-W4A and 802T-W4C
Shipping Wt. 57g (2oz)

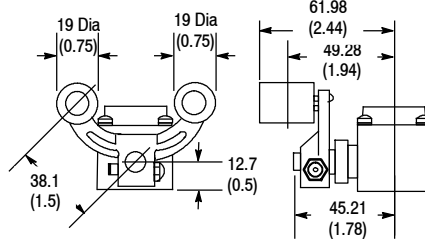

802T-W4F
Shipping Wt. 57g (2oz)

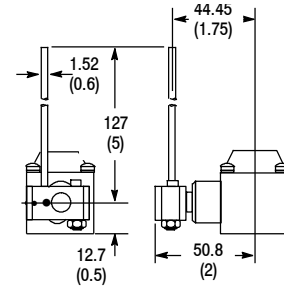

802T-W5
Shipping Wt. 28g (1oz)

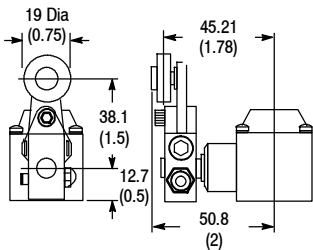

802T-W6, 802T-W6A,
802T-W6B, 802T-W6E
Shipping Wt. 57g (2oz)

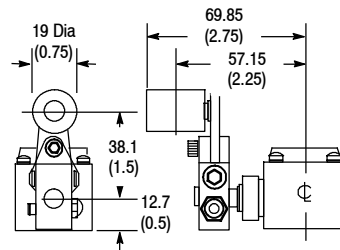

802T-W6F
Shipping Wt. 57g (2oz)

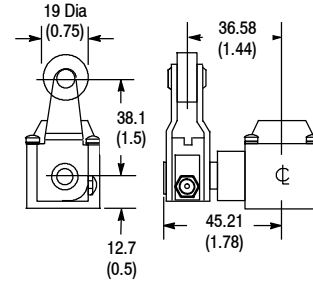

802T-W7, 802T-W7A
and 802T-W7B
Shipping Wt. 57g (2oz)

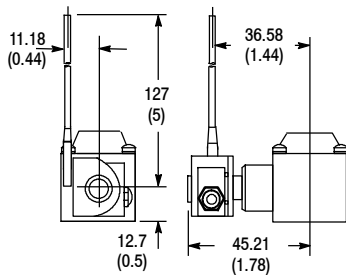

802T-W8
Shipping Wt. 43g (1.5oz)

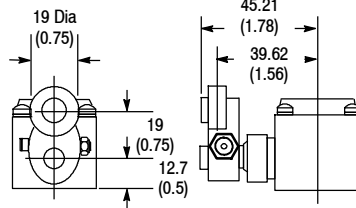

802T-W9
Shipping Wt. 28g (1oz)

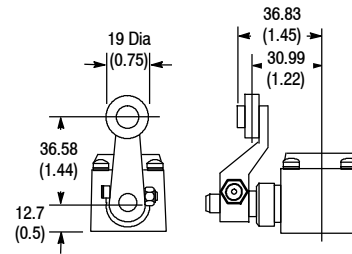

802T-W12 Shipping Wt. 1 oz. and
802T-W12A 802T-W6B, 802T-W6E
Shipping Wt. 43g (1.5oz)

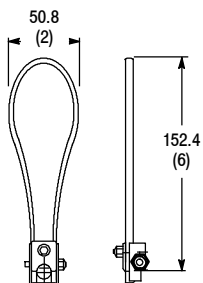

802T-W14
Shipping Wt. 43g (1.5oz)

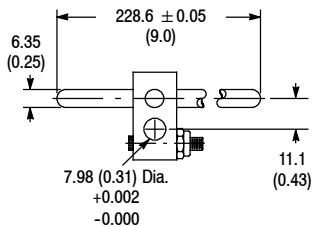

802T-W16
802T-W16A

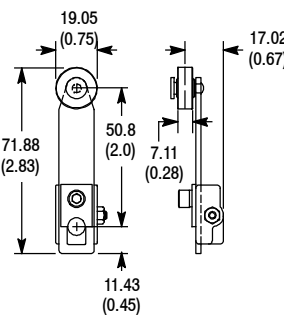

802T-W20
Shipping Wt. 57g (2oz)

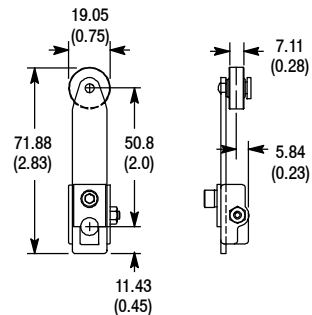

802T-W20J
Shipping Wt. 57g (2oz)